

An abstract geometric pattern in the upper left corner, composed of overlapping, semi-transparent blue and white shapes that resemble a stylized leaf or a fan.

Technische Universität München

Institute for Advanced Study

2012

A large, abstract, wavy pattern at the bottom of the cover, featuring concentric, irregular shapes in shades of blue, white, and yellow-green, resembling a topographic map or a fluid flow visualization.



Annual Report

Technische Universität München

Institute for Advanced Study

2012

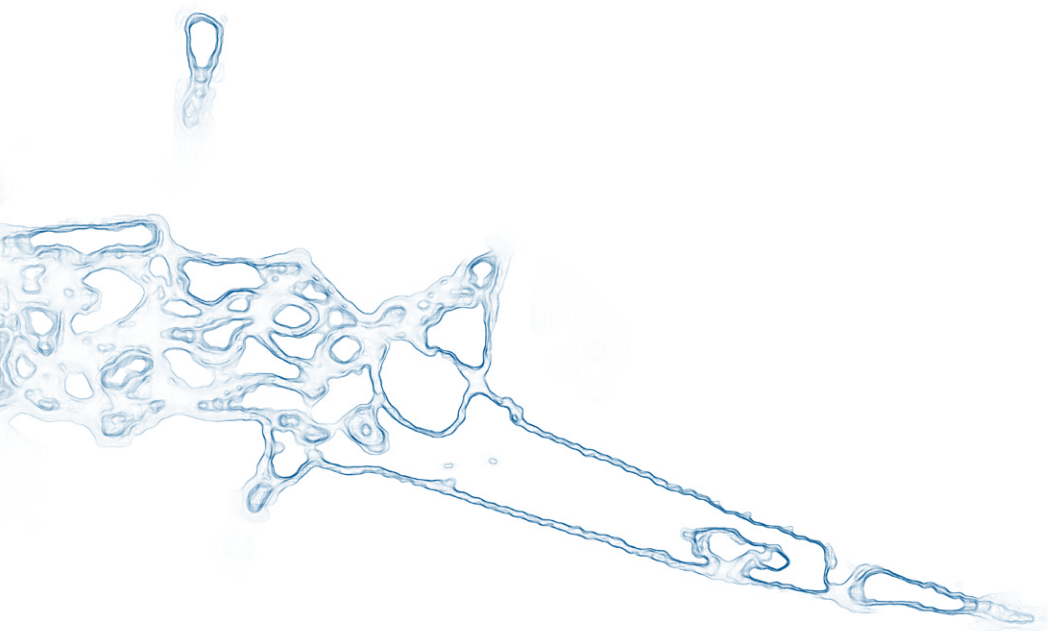

Table of Contents

TUM President's Foreword	4
TUM-IAS Director's Message	6
2012 Overview	9
New Fellows and their Research	19
Highlights and Achievements	33
In Focus: Group Interview	97
Five Years TUM-IAS: A View	111
Institute Activities	119
People	131
Index	140



Our university's competitive success in the second round of the German Excellence Initiative, announced midway through 2012, is in large measure an endorsement of ideas embodied in the TUM Institute for Advanced Study: global perspectives on scientific and societal challenges, international orientation and action, excellence and interdisciplinarity, and creative approaches to high-risk / high-reward research.

The TUM-IAS was by no means the only part of the TUM community pressing ahead on these fronts over the past few years, but it has served – as we expected it would – to lead the way and push the boundaries. Naturally, ensuring continuity for this increasingly independent yet still-young institute is one of the measures supported by the roughly 165 million euros awarded to TUM for the second Excellence Initiative funding period. Our International Graduate School of Science and Engineering, forerunner of the overarching TUM Graduate School, also won continuing support, as did four of the Excellence Clusters in which TUM is a leading participant. The newly funded Munich Cluster for Systems Neurology (SyNergy) actually has roots in the Institute for Advanced Study, as it stems in part from the scientific creativity and entrepreneurial spirit of co-coordinator Prof. Thomas Misgeld, a Hans Fischer Tenure Track Fellow of the TUM-IAS.

Among the newer Excellence Initiative measures, the TUM-IAS is now flanked by three more integrative research centers, thematically oriented networking

hubs that facilitate cooperation across departmental and other traditional boundaries. The Munich School of Engineering prepares engineers of the future through interdisciplinary research and teaching, focused on areas such as sustainable energy solutions, industrial biotechnology, and infrastructure. The Munich Center for Technology in Society provides a framework for examining and possibly influencing the interplay of innovation with societal needs and values. The MCTS engages philosophers, sociologists, economists, political scientists, historians, and media scholars in this effort, as well as researchers from TUM's core disciplines of science and engineering. Finally, the Anna Boyksen Diversity Research Center is spearheading our exploration of issues and opportunities associated with human diversity. Recognizing that today's science and engineering cultures still do not fully integrate – or benefit from – talents in all their diversity, we hope that TUM can contribute to a new culture built on cooperation and mutual respect.

Talents are front and center in the university's new recruitment and career development system. From an innovative program aimed at attracting international postdocs to a headhunting procedure to seek out established “star talent,” TUM is taking a fresh approach to recruiting. This is a strategic thrust aimed at transforming the TUM faculty – to make it younger and more international overall, with a larger percentage of female professors – and the Excellence Initiative has provided a strong push for a fast start.

Eight new professorships are designated specifically for distinguished women in science and engineering. Furthermore, TUM has instituted Germany's first true end-to-end tenure track system and is committed to creating 100 new tenure track professorships by the year 2020. Here too, the Institute for Advanced Study has pioneered new ideas for bringing some of the world's best minds to TUM and is participating directly in the new system via the Rudolf Mößbauer Tenure Track Professorship.

This report is primarily a chronicle of one year's achievements. But since 2012 was Prof. Patrick Dewilde's last full year as Director, we really ought to think back over the Institute's entire history and try to appreciate his distinctive personal contribution. In 2005, the TUM-IAS was little more than words on a page. In bringing this grand idea to life, many excellent advisors, scientists, and staff members have played vital roles. But I think all would agree that no one has done more, or more permanently impressed the Institute with the stamp of an individual character, than Patrick Dewilde. Personally and on behalf of the entire TUM community, I want to express our deepest thanks and admiration.



Prof. Wolfgang A. Herrmann
President

TUM-IAS Director's Message

6 Let me start by congratulating our President, Prof. Wolfgang A. Herrmann, and TUM on the success in the second phase of the Excellence Initiative. The institutional strategy "TUM. The Entrepreneurial University" shows a substantiated view on the future of our university. In an impressive show of purpose TUM convinced a very critical international jury of its cohesion, its scientific and technological abilities, and its innovative view on its future development. Needless to say, our Institute has to play a substantial role in helping to realize all these ambitions.

A viable "Institutional Strategy" will base itself on a keen analysis of opportunities and shortcomings, mending the latter and promoting the former. A first line of force in the TUM proposal was the strengthening of the number and outlook for junior professors through the creation of an effective tenure track system; a second, the inclusion of the "societal dimension" in technology and engineering; a third, the further grooming of the "international dimension" of our university. In all cases, TUM-IAS will strongly participate: It will award 14 "Rudolf Mößbauer Tenure Track Fellowships" in the coming five years, support the newly created Munich Center for Technology in Society and other efforts to increase the societal relevance of its research, and further its already intensive long-term international cooperation programs through Hans Fischer and Rudolf Diesel Industry Fellows. This is what the future will bring.

Concerning the past: 2012 has been a good year for TUM-IAS. Not only did it participate strongly in the new plans for the Excellence Initiative, it was also awarded a large grant from the EU through the Marie Curie COFUND program that greatly contributes to its international fellowship program. Even though the first

round of the Excellence Initiative came to an end, we were able to award four Hans Fischer and three Rudolf Diesel Industry Fellowships.

2012 saw the departure of quite a few Fellows whose tenure had come to an end. A number of Carl von Linde Junior Fellows whose careers the Institute has helped to launch have produced impressive results and achieved prominent positions, mostly elsewhere. Also many of our first-generation Hans Fischer Senior Fellows and Rudolf Diesel Industry Fellows saw their active term end in 2012. Together with our first-generation Carl von Linde Senior Fellows, they and their Hosts must be credited with shaping the Institute scientifically. A necessarily short Director's message cannot do justice to the manifold of results, ideas and leadership they brought to TUM. The development of world-class science and technology depends in good measure on the import of expertise from our colleagues at other universities and research centers. To be effective, one has to assemble all the multidisciplinary expertise needed. Luckily, the end of an active Fellowship tenure is not the end of the collaboration: The TUM-IAS Fellowship is an award that remains valid forever, and we shall always welcome our Fellows and appreciate their continuous interest in collaborating with TUM.

An additional special word of appreciation should go to our Carl von Linde Senior Fellows whose term of tenure has ended: They have been the backbone of the Institute in its first five years of existence. Not only have they been leading major research efforts that have made the scientific reputation of our Institute and TUM, they have also served as highly competent and trusted members of our Advisory Council, providing guidance to me and our Program Managers. I experience the ending of their active Fellowship term as a

big loss, but as our mission is to permanently renew and re-seed, we have to move on to new nominations. Andrzej Buras, Axel Haase, Claudia Klüppelberg, Arthur Konnerth, Reiner Rummel, Ulrich Stimming, the Institute owes a lot to you all. Luckily, I know that it can still count on your advice and help at any time, especially when the going gets tough.

So many people have contributed to the Institute's well-being and successes in 2012, and I am very hard-pressed to thank them all effectively. This report presents a good number of highlights, contributed scientific results and Fellow presentations; I will not repeat those here, but I wish in particular to thank them all for the magnificent presentations of their work that they provided during the visit of the evaluation committee for the second phase of the Excellence Initiative. Our Advisory Council has been very active in advising on scientific directions and participating in the activities of the Institute. My thanks also go to our Board of Trustees members for their continuous support, the TUM Board of Management for the very intimate and productive collaboration in shaping and defending our Excellence Initiative proposal, and the Deans of Faculties for hosting our Fellows enthusiastically.

Some of our advisors deserve special consideration for the critical role they played in some major decisions. Let me mention (in alphabetic order and besides our President and Senior Vice President for Administration and Finance): Gerhard Abstreiter, Joachim Hagenauer, Thomas Hofmann, Klaus Mainzer, Jürgen Mittelstraß, Dianne Newell, Ernst Rank, Frank Talke and Peter Wilderer. Thank you for what you did for us; I could always call and count on you, but you also contributed many things to the Institute without my asking.

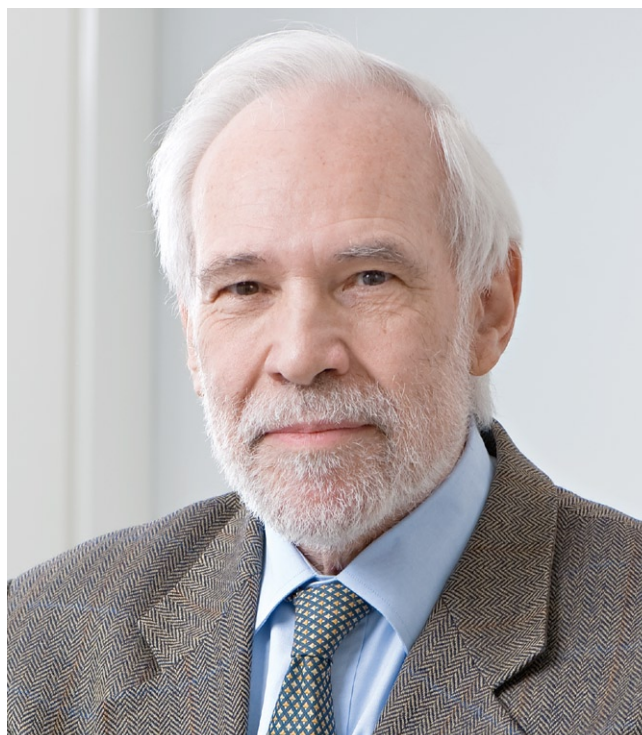

But the people I could count most on have been our wonderful staff. It is hardly imaginable how an Institute like TUM-IAS could function without the support of an excellent team. The range of activities of the team is very widespread and requires not only a clever division of responsibilities, but also a keen sense of mutual support and collaboration: one for all and all for one.

As I will retire in 2013 as Director, I shall miss you all very much.

Prof. Patrick Dewilde
Director



2012 Overview

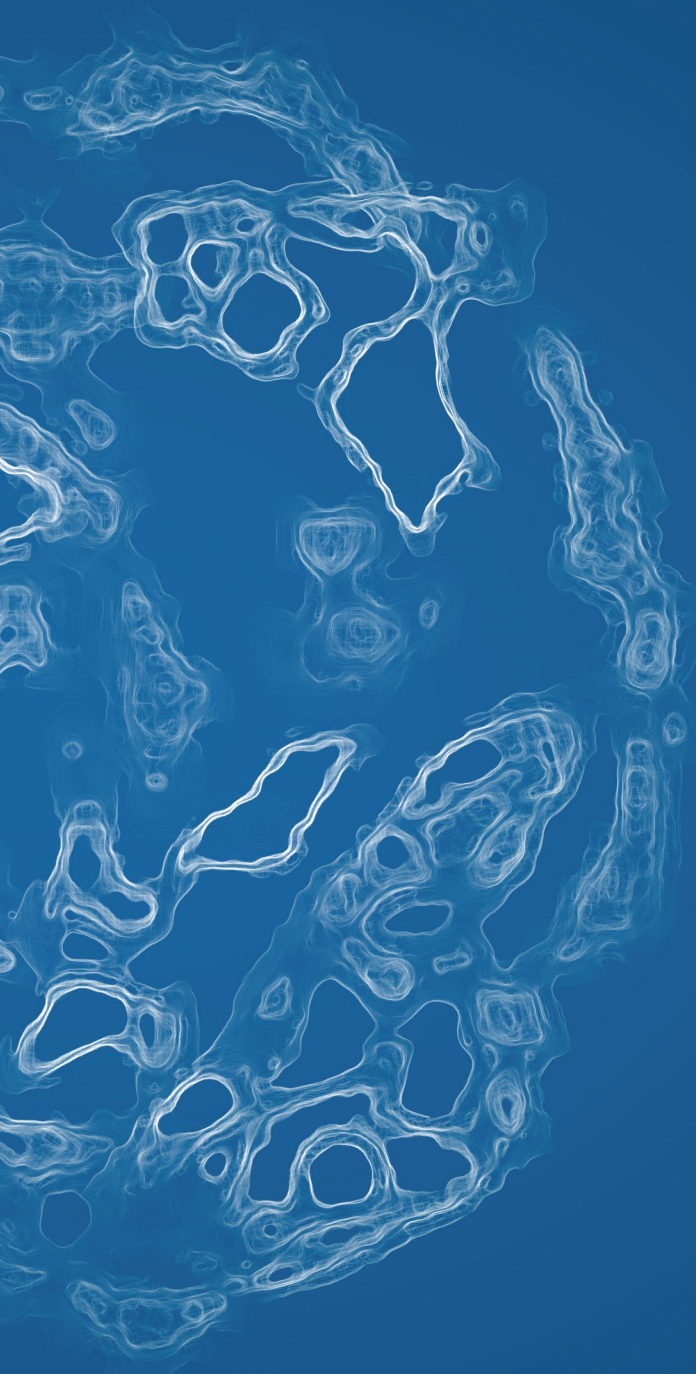

10 2012 Overview

TUM-IAS has awarded seven new Fellowships in 2012, among them two Hans Fischer Senior Fellows and for the first time two Hans Fischer Junior Fellows as well as three Rudolf Diesel Industry Fellows.

The TUM-IAS Fellows come from diverse disciplines and from 12 different countries.

Support for the TUM-IAS Fellows includes funding of more than 60 doctoral candidates and around 10 postdoctoral researchers, who collaborate closely with them.

About 10 doctoral candidates have already finished their PhD thesis while being a member of TUM-IAS, working on topics such as “Wholesale Energy Market in a Smart Grid: Dynamic Modeling, Stability and Robustness” (Arman Kiani, Focus Group Networked Dynamical Systems), “Extremal Behavior of Multivariate Mixed Moving Average Processes and of Random Walks with Dependent Increments” (Martin Moser, Focus Group Risk Analysis and Stochastic Modeling) or “Enhanced Spontaneous Emission from Silicon-based Photonic Crystal Nanostructures” (Norman Hauke, Focus Group Nanophotonics).

Total Number of TUM-IAS Fellows

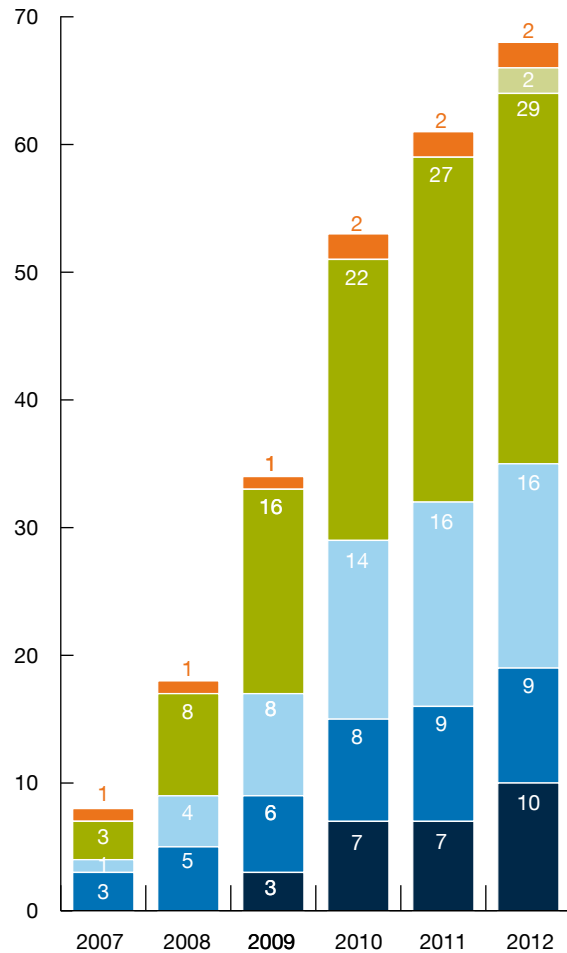

Distribution According to Faculties

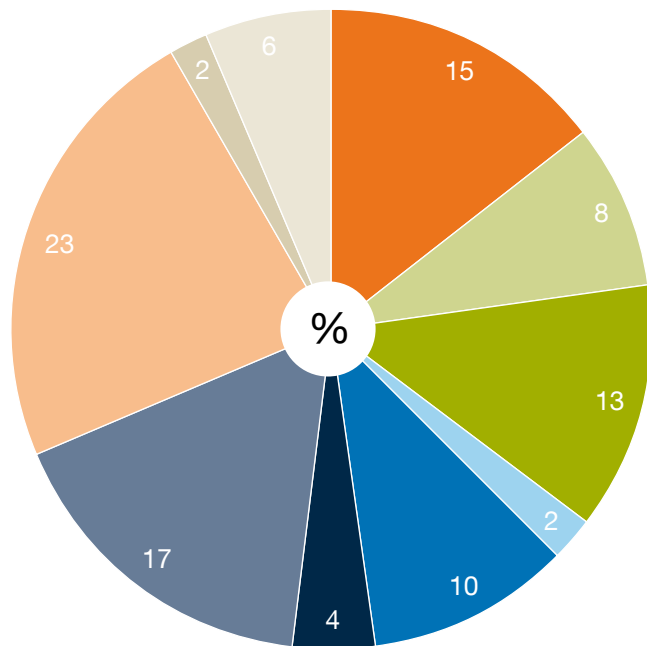

Distribution According to Main Scientific Fields

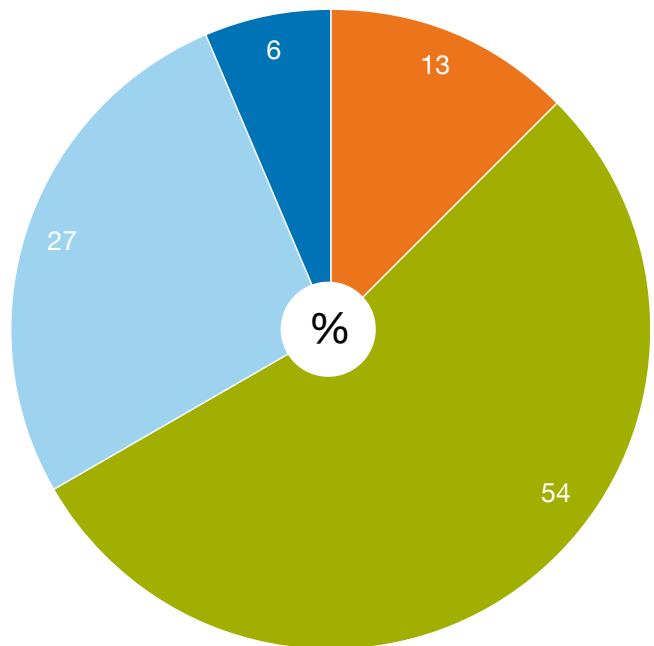

- Informatics
- Chemistry
- Medicine
- Mathematics
- Mechanical Engineering
- Civil Engineering
- Physics
- Electrical Engineering
- Architecture
- Center of Life and Food Sciences Weihenstephan

- Medicine
- Engineering
- Natural Sciences
- Life Sciences

Where do the TUM-IAS Fellows come from?

12

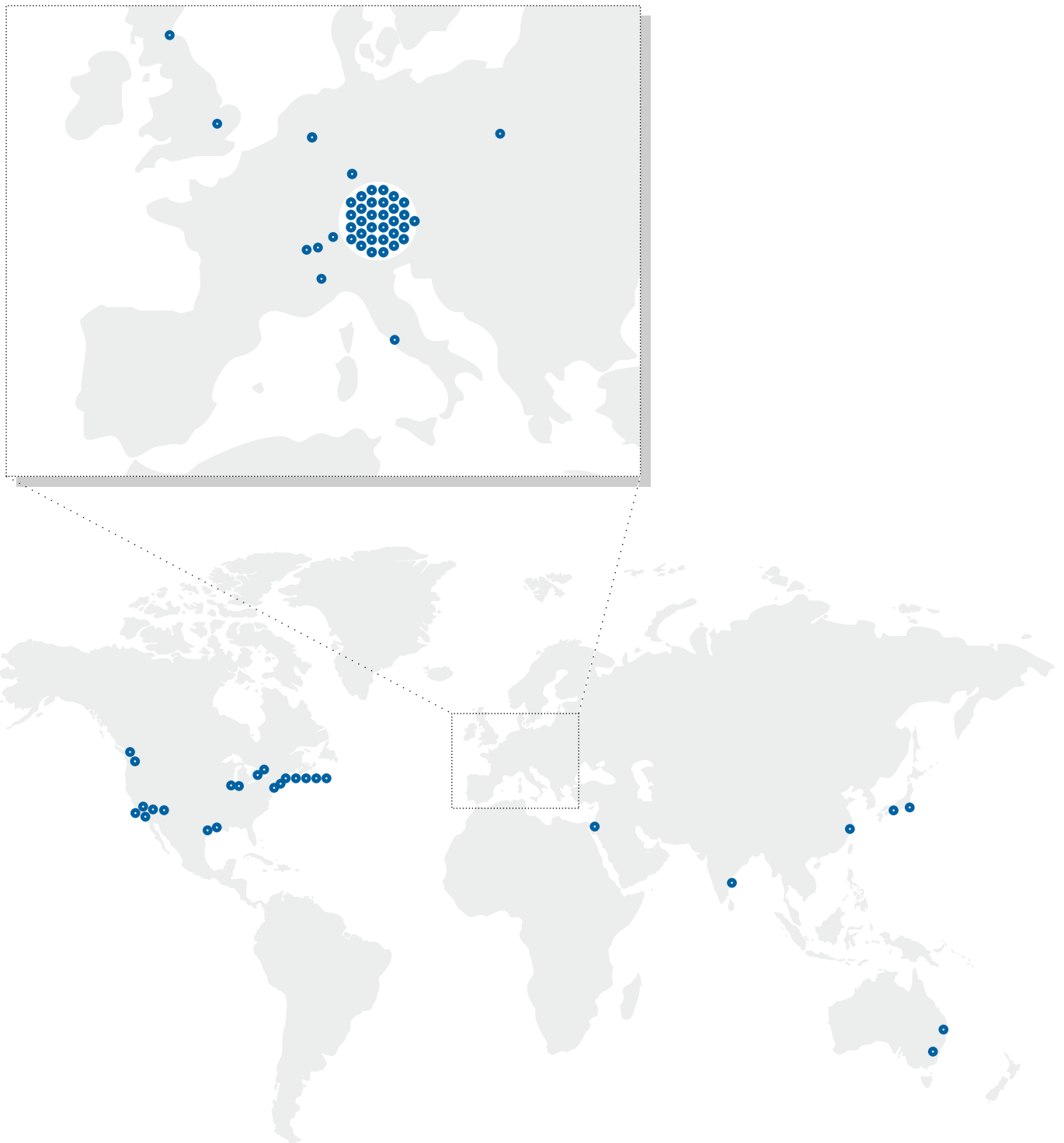

Focus Groups

TUM-IAS Focus Groups are the basic units of organization of the Institute. They are fully integrated in TUM and provide the social environment where Fellows, Hosts, their students, and collaborators meet to share the development of their topic, organize activities, and give mutual support. Ideally, these teams are also diverse in terms of disciplines and gender.

Advanced Cardiac Mechanics Emulator

Prof. Michael Ortiz | California Institute of Technology, USA

PhD: Andreas Nagler

Postdoc: Dr. Cristóbal Bertoglio

Host: Prof. Wolfgang A. Wall | Computational Mechanics, TUM

Advanced Computation

Prof. Matthew Campbell | University of Texas, USA

PhD: Amir Hooshmand

Host: Prof. Kristina Shea | Product Development, TUM (now ETH Zurich)

Prof. Peter Schröder | California Institute of Technology, USA

PhD: Jan Stühmer

Host: Prof. Rüdiger Westermann | Computer Graphics and Visualization, TUM

Advanced Construction Chemicals and Materials

Dr. Tsuyoshi Hirata | Nippon Shokubai, Ltd., Japan

PhD: Alex Lange

Host: Prof. Johann Plank | Construction Chemicals, TUM

Advanced Stability Analysis

Dr. Bruno Schuermans | Alstom, Switzerland

Prof. Raman I. Sujith | Indian Institute of Technology Madras

PhD: Ralf Blumenthal, Sebastian Bomberg

Hosts: Prof. Wolfgang Polifke, Prof. Thomas Sattelmayer | Thermodynamics, TUM

Aircraft Stability and Control

Dr. Matthias Heller | CASSIDIAN, EADS Deutschland GmbH

PhD: Markus Geiser

Host: Prof. Florian Holzapfel | Flight System Dynamics, TUM

Biochemistry

Dr. Franz Hagn | Harvard Medical School, USA

Host: Prof. Horst Kessler | Chemistry, TUM

Biomedical Engineering

Prof. Axel Haase | TUM

PhD: Thomas Gaaß, Marika Kuschan

Host: Prof. Markus Schwaiger | Clinic for Nuclear Medicine, TUM

Biophysics

Prof. Robijn Bruinsma | University of California, Los Angeles, USA

Prof. Hendrik Dietz | TUM

PhD: Thomas Gerling, Heinrich Grabmayr

Host: Prof. Andreas Bausch | Molecular and Cellular Biophysics, TUM

Clinical Cell Processing and Purification

Prof. Stanley Riddell | University of Washington, Seattle, USA

Dr. Christian Stemberger | TUM

PhD: Jeannette Bet, Paulina Paszkiewicz

Postdoc: Dr. Stefan Dreher

Host: Prof. Dirk Busch | Medical Microbiology, Immunology and Hygiene, TUM

Cognitive Technology

Prof. Alexandra Kirsch | University of Tübingen

Dr. Kolja Kühnlenz | Bayerisches Landesamt für Maß und Gewicht

Prof. Dongheui Lee | TUM

Dr. Angelika Peer | TUM

Dr. Georg von Wichert | Siemens, Munich

Dr. Dirk Wollherr | TUM

PhD: Barbara Kühnlenz, Michael Karg, Christina Lichtenthäler, Andreas Schmid, Bernhard Weber, Liu Ziyuan

Host: Prof. Martin Buss | Automatic Control Engineering, TUM

Computational Biomechanics

Prof. Zohar Yosibash | Ben-Gurion University, Israel

PhD: Hagen Wille

Host: Prof. Ernst Rank | Computation in Engineering, TUM

C-H Activation Chemistry

Prof. Polly L. Arnold | University of Edinburg, UK

PhD: Max McMullon

Host: Prof. Fritz Kühn | Molecular Catalysis, TUM

Fiber-Optic Communication and Information Theory

Dr. René-Jean Essiambre | Bell Labs,
Alcatel-Lucent, USA

Prof. Frank Kschischang | University of Toronto,
Canada

Postdoc: Dr. Luca Barletta, Dr. Mansoor Yousefi

Host: Prof. Gerhard Kramer | Communications
Engineering, TUM

Fundamental Physics

Prof. Gino Isidori | Frascati National
Laboratories, Italy

Prof. Stefan Pokorski | University of Warsaw, Poland

PhD: Emmanuel Stamou

Postdoc: Dr. Jennifer Girrbach, Dr. Luca Merlo,
Dr. Robert Ziegler

Host: Prof. Andrzej Buras | Physics, TUM

Global Change

Prof. Tim Sparks | Coventry University,
University of Cambridge, UK

PhD: Anna Bock, Julia Laube

Postdoc: Dr. Nicole Estrella, Dr. Susanne Jochner,
Dr. Christian Zang

Host: Prof. Annette Menzel | Ecoclimatology, TUM

High-Performance Computing (HPC)

Prof. George Biros | University of Texas at Austin, USA

Prof. Markus Hegland | Australian National University

Dr. Miriam Mehl | TUM

PhD: Christoph Kowitz, Valeriy Khakhutskyy,
Benjamin Uekermann

Research Member: Prof. Dirk Pflüger | University
of Stuttgart

Host: Prof. Hans-Joachim Bungartz | Scientific
Computing, TUM

Intra-Operative Therapy

Dr. Michael Friebe | IDTM GmbH, Bochum

Host: Prof. Nassir Navab | Computer Aided Medical
Procedures and Augmented Reality, TUM

Metropolis Nonformal

Prof. Christian Werthmann | Harvard University, USA

PhD: Gokce Iyicil

Host: Prof. Regine Keller | Landscape Architecture
and Public Space, TUM

Molecular Imaging

Prof. Silvio Aime | University of Turin, Italy

PhD: Giaime Rancan

Host: Prof. Markus Schwaiger | Clinic for Nuclear
Medicine, TUM

Networked Dynamical Systems

Dr. Dragan Obradovic | Siemens, Munich

PhD: Arman Kiani, Herbert Mangesius, Harald Voit

Host: Prof. Sandra Hirche | Information-Oriented
Control, TUM

Neuroscience

Prof. Thomas Misgeld | TUM

PhD: Rita Förster

Host: Prof. Arthur Konnerth | Neuroscience, TUM

Regenerative Medicine

Prof. Dietmar Hutmacher | Queensland University of
Technology, Australia

Host: Prof. Arndt Schilling | Clinic for Plastic Surgery
and Hand Surgery, TUM

Soil Architecture

Prof. Ingrid Kögel-Knabner | Soil Science, TUM

Postdoc: Dr. Geertje Pronk

Host: Soil Science, TUM

Statistical and Quantitative Genomics

Prof. Daniel Gianola | University of Wisconsin-Madison, USA

PhD: Christos Dadousis

Host: Prof. Chris-Carolin Schön | Plant Breeding, TUM

Risk Analysis

Engineering Risk Analysis

Dr. Chin Man W. Mok | AMEC Geomatrix, Inc., Oakland, USA

PhD: Wolfgang Betz

Host: Prof. Daniel Straub | Engineering Risk Analysis, TUM

Risk Analysis and Stochastic Modeling

Prof. Richard Davis | Columbia University, USA

PhD: Martin Moser, Oliver Pfaffel, Eckhard Schlemm, Christina Steinkohl, Florian Ueltzhöfer

Host: Prof. Claudia Klüppelberg | Mathematical Statistics, TUM

Energy and Electromobility

Diesel Reloaded

Prof. Gernot Spiegelberg | Siemens, Munich

PhD: Claudia Buitkamp, Ljubo Mercep, Hauke Stähle

Host: Prof. Alois Knoll | Robotics and Embedded Systems, TUM

Molecular Aspects in Interface Science

Dr. Julia Kunze-Liebhäuser | TUM

PhD: Norbert Kluy, Celine Rüdiger, Christoph Traunsteiner

Host: Prof. Ulrich Stimming | Physics, TUM

Nanoscience

Functional Nanosystems

Prof. Shuit-Tong Lee | Soochow University, China

PhD: Matthias Sachsenhauser

Host: Prof. Martin Stutzmann | Experimental Semiconductor Physics, TUM

Nanoimprint and Nanotransfer

Prof. Khaled Karrai | attocube Systems AG, Munich

Prof. Wolfgang Porod | University of Notre Dame, USA

PhD: Edgar-Otto Albert, Mario Bareiß, Armin Exner,

Qingqing Gong, Muhammad Atyab Imtaar,

Klaus Thurner, Anandi Yadav

Host: Prof. Paolo Lugli | Nanoelectronics, TUM

Nanophotonics

Prof. Gerhard Abstreiter | TUM

PhD: Matthias Firnkes, Stefan Funk, Markus Schuster, Alexander Schwemer, Sara Yazji, Thomas Zabel

Postdoc: Dr. Eric Hoffmann

Host: Experimental Semiconductor Physics, TUM

Nanoscale Control of Quantum Materials

Dr. Willi Auwärter | TUM

Host: Prof. Johannes Barth | Molecular Nanoscience and Chemical Physics of Interfaces, TUM

Nanoscience for Renewable Energy Sources

Prof. Stephen Goodnick | Arizona State University, USA

Host: Prof. Paolo Lugli | Nanoelectronics, TUM

Nonequilibrium Statistical Mechanics at the Nanoscale

Dr. Vladimir García Morales | TUM

PhD: Lennart Schmidt

Host: Prof. Katharina Krischer | Nonequilibrium Chemical Physics, TUM

In this section a brief survey of the financial data is given. All expenditures of TUM-IAS are covered by the “third funding line” of the Excellence Initiative. In 2012, we have maintained approximately the same level of expenditures as in the previous year, continuing a steady state on full capacity of the Institute with 68 Fellows.

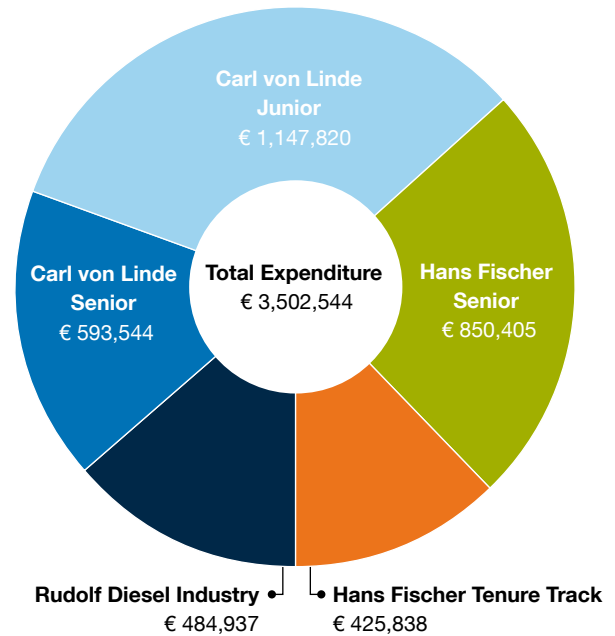

The first chart shows the expenditures in 2012, in the different Fellowship categories. As previously, the contribution to the internationalization of TUM is quite visible, as 25% of the total costs were spent on the TUM-IAS Hans Fischer Senior Fellowships. These Fellowships are an important and successful contribution to the TUM internationalization strategy and are immensely valuable regarding the exchange of complementary expertise and grooming of emerging fields. The category which dominates the program in costs is the Carl von Linde Junior Fellowship, showing again the emphasis TUM-IAS places on funding very promising young scientists by giving them the opportunity to develop their own ideas and research independently.

The increase in this category as compared to the previous year is mostly due to the fact that the positions of the doctoral candidates coached by the Junior Fellows are now accounted for in the chart instead of in the Start-up Funding. In return, the Carl von Linde Senior Fellowship shows less expenditure this year, mainly because some Fellows terminated their tenure in 2011, and also because it has been established in 2010 that only one Fellow per year is to be nominated in this category. The Rudolf Diesel Industry category shows a steady increase in expenditures, as the nominations of 2010 are fully active and operational.

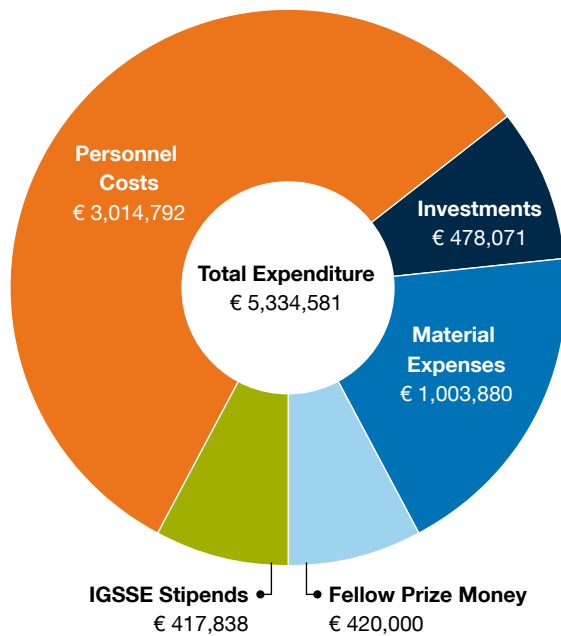
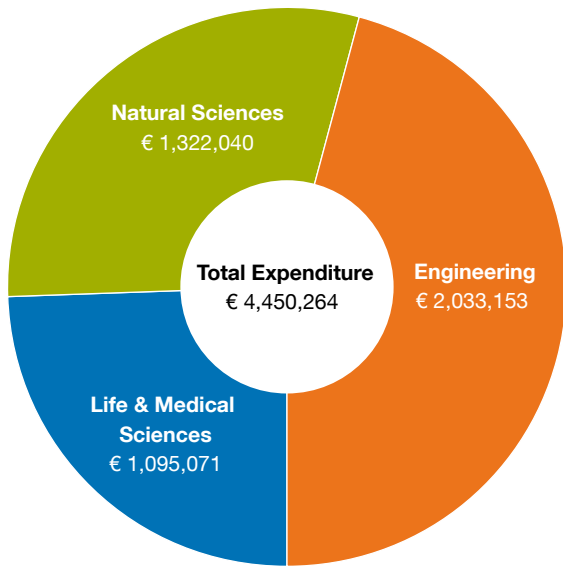

This chart shows the expenditures of the different TUM-IAS Fellowships grouped into the TUM scientific fields, as well as the expenditures from the Start-up and Visiting Fellowship program according to scientific fields. Interdisciplinary projects were classed according to their most dominant field. Engineering superseded natural sciences as the most strongly represented field at TUM-IAS (especially electrical engineering with 13 Fellows). But there was growth in the life sciences and medicine as well, reflecting the Institute's efforts to cover the various areas of expertise at TUM. The expenditures per main scientific field are virtually identical to the distribution of Fellows according to main scientific field (see the pages 10/11 "2012 Overview")

The total expenditures reached approximately the same level as in 2011, due to full capacity operation of the Institute. It has become the policy of the Institute to offer working contracts to doctoral candidates (instead of stipends), and this is reflected in an increase in personnel costs and a decrease in expenditures for IGSSE stipends.



New Fellows and their Research

C-H Activation Chemistry

Cognitive Technology

Molecular Imaging

Statistical and Quantitative Genomics



New Fellows and their Research

Since the Institute's very beginning, every year a couple of new faces have joined the community and contributed to the diversity that makes the TUM-IAS community so enriching and unique. In 2012, too, a number of promising new projects were kicked off by five recently affiliated Fellows, three of whom being Hans Fischer Senior Fellows, two of them Carl von Linde Junior Fellows.

Prof. Polly L. Arnold of the University of Edinburgh was awarded the Hans Fischer Senior Fellowship on proposal of Prof. Fritz Kühn, on the all-important topic of catalytic conversion of C-H bonds in hydrocarbons. Generating new ideas in this domain will strengthen the already large efforts TUM and the TUM-IAS are putting into solving catalysis problems for a variety of environmentally relevant applications (treatment of hydrocarbons, battery technology, fuel cells). This activity will also mesh well with our general interest in advanced molecular imaging.

Molecular imaging and *in vivo* visualization of molecules is the topic of our Hans Fischer Senior Fellow Prof. Silvio Aime of the University of Torino, hosted by Prof. Markus Schwaiger of the Clinic for Nuclear Medicine. Prof. Aime is a great specialist in using well chosen chemo-physical phenomena to improve MRI imaging, a field that has already received great attention in our Institute via IMETUM (Institute of Medical Engineering), presently headed by our Carl von Linde Senior Fellow, Prof. Axel Haase. Prof. Aime's participation in our Institute will greatly contribute not only to that field, but also to the multidisciplinary interactions required to further improve on the already all important diagnostic and spectroscopic MRI imaging methodology.

In another molecular direction, but equally central in the activities of the Institute, is the Hans Fischer Senior Fellowship Award to Prof. Daniel Gianola of the University of Wisconsin-Madison on proposal of Prof. Chris-Carolin Schön, to develop novel methods of (statistical) phenotyping, in order to greatly improve plant selection based on genomic properties (genes are now easily and cheaply determined, but what is the ensuing phenotype?). The collaboration of this group of researchers with our activities in the area of statistical analysis has been exemplary and leading to advanced but very applicable algorithms. It is amazing to see how these biology researchers have become signal processing specialists on a par with the best telecommunication engineers!

A different large area of attention both at TUM and in our Institute is Cognition. Two new Carl von Linde Junior Fellowships in this area were proposed, both by Prof. Martin Buss. Both of them won the competition hands down in our Delphi procedure: Prof. Dongheui Lee with strong new ideas on how to make a learning robot and then how to teach it by imitation (more or less like a young child is doing); and Dr. Angelika Peer, who will focus on the interplay between haptic interaction and mental collaboration. These two young researchers will strengthen the already extensive activities in the Focus Group Cognitive Technology, importing important new viewpoints and underscoring the intense multidisciplinary interactions needed to understand how robotic intelligence and cognition could be brought to a level somewhat closer to human.

Focus Group C-H Activation Chemistry

Prof. Polly L. Arnold | Hans Fischer Senior Fellow

Max McMullon | Doctoral Candidate

© Prof. Fritz Kühn, Molecular Catalysis, TUM

22 New Fellows and their Research

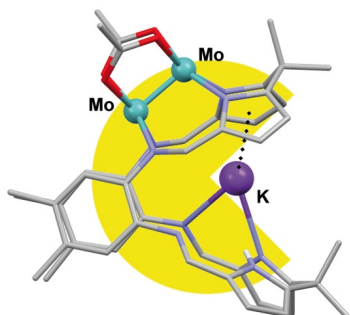

Taming nature's most reactive metals to break carbon-hydrogen bonds

The vision of this Focus Group is to develop world-leading research in the form of the first useful catalytic conversion of the C-H bonds in hydrocarbons such as petrol or biomass, to more interesting functional groups, by the application of our molecular systems.

The Focus Group started just a few months ago, but already students, postdocs, staff, ideas, and catalyst samples are moving freely, and in increasing numbers, between Edinburgh and Munich. With preliminary results, we are preparing publications for high-quality international journals, and have already levered postdoctoral funding for additional collaborative work.

Burning petrol and other hydrocarbons from fossil fuels is damaging to the environment and wasteful of resources that could otherwise be used to make substances that improve the quality of life. However, the strength of the carbon-hydrogen bond, coupled with the difficulties associated with selectively accessing a specific site on a particular molecule, means that highly reactive metal compounds are needed to catalyze such processes.

In addition to the tantalizingly simple, single C-H bond in methane, the most abundant hydrocarbon, the activation of C-H bonds in more complex hydrocarbons is also a highly desirable 'toolbox' component for scientists working in all areas of chemical synthesis. This selectivity will become increasingly more important as our palette of platform chemicals changes from fossil fuel-derived to biomass-derived in the coming years.

Hydrocarbon-soluble compounds of the lanthanides and actinides first gave a glimpse of their potential with the selective cleavage of one C-H bond in methane some 25 years ago, but the limitations of the supporting molecular structures precluded any further functionalization step. Since then, a variety of C-H bond activation chemistry has been demonstrated using molecules that harness these metal cations, but not yet provided profitable applications.

The Focus Group program builds on our recent proof-of-concept results in three areas:

- The use of carbene ligands on f-block complexes to couple carbon monoxide and deoxygenate carbon dioxide (J. Am. Chem. Soc. 2011), form carbon-carbon and carbon-silicon bonds (J. Am. Chem. Soc. 2010).
- The use of molecular frameworks to harness unprecedented reactivity of U=O oxo groups towards C-H and N-Si bond cleavage (Nature, 2008, Nature Chem. 2010).
- Our development of a mild, new cooperative new mechanism for converting C-H bonds of arenes (aromatic molecules that make up the heavier fractions of crude oil) into C-B bonds. (Nature Chem. 2012).

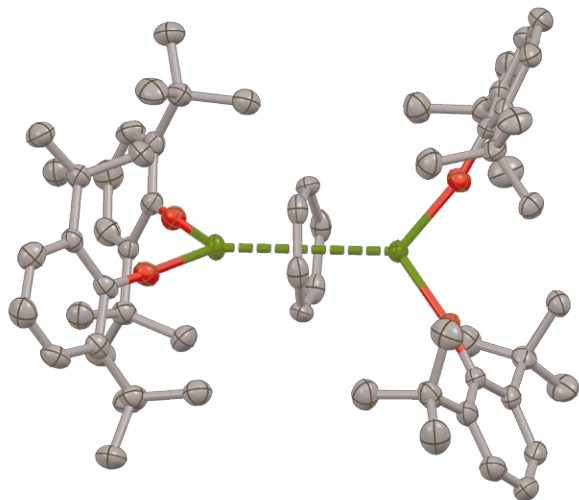

1 | Reactive metal cations have been harnessed by a series of organic framework ligands in order to control the selective conversion of a single, unreactive C-H bond into a useful functional group.

The primary doctoral candidate, Max McMullon, has made a new ligand framework to bind complementary metals, combining the C-H bond activation and selective oxidation steps by retaining both Ce (the important catalytic component for O shuttling in many catalysts, such as those in car exhausts), and a transition metal cation (for C-H activation). The other PI in our lab, Dr. Jason Love, is also now collaborating with Prof. Fritz Kühn on metal oxo chemistry of Pacman macrocycles, especially with Cr, Mo, and W, to reduce small molecules such as dinitrogen, a key target for low-energy conversion to fertilizers and drug precursors, and carbon dioxide, an important renewable feedstock. New methods for encapsulating the industrially important MTO catalyst, used for hydrocarbon oxidation, are also being pursued, in collaboration with Dr. Love, on the use of novel receptors in biphasic oxidation catalysis.

Selected Publications

- [1] P. L. Arnold, G. M. Jones, S. Odoh, G. Schreckenbach, N. Magnani, and J. B. Love, "Strongly-coupled, binuclear uranium oxo complexes from uranyl oxo-rearrangement and reductive silylation," *Nature Chem.*, vol. 4, pp. 221–227, 2012.
- [2] P. L. Arnold, S. M. Mansell, L. Maron, and D. McKay, "Spontaneous reduction and C-H borylation of arenes mediated by uranium(III) disproportionation," *Nature Chem.*, vol. 4, no. 8, pp. 668–674, 2012.



Polly L. Arnold FRSE FRSC

obtained a BA from Oxford in 1994 and DPhil in 1997 from Sussex. She was awarded a Fulbright Scholarship for postdoctoral research at MIT, and returned to the UK to a lectureship at the University of Nottingham in 1999. She moved to the University of Edinburgh in 2007, and was promoted to Chair in 2009. She is currently an EPSRC Leadership Research Fellow. Other recent research awards include the Bessel Prize from the Humboldt Foundation, and the Chancellor's prize of the University of Edinburgh. In the last year, she has been awarded the Rosalind Franklin medal by the Royal Society, the Corday-Morgan prize by the Royal Society of Chemistry, and elected a Fellow of the Royal Society of Edinburgh (FRSE) and a Fellow of the Royal Society of Chemistry (FRSC).

Skill transfer from humans to robots

Robot programming by demonstration provides an efficient way for a robot to learn new skills through human teaching, which can reduce time and cost to program the robot. In this work, we have developed algorithms for teaching a robot intuitively to complete various tasks. In the following paragraphs, I will describe some concepts for teaching dynamic tasks which involve interaction with objects, the environment, and a human user.

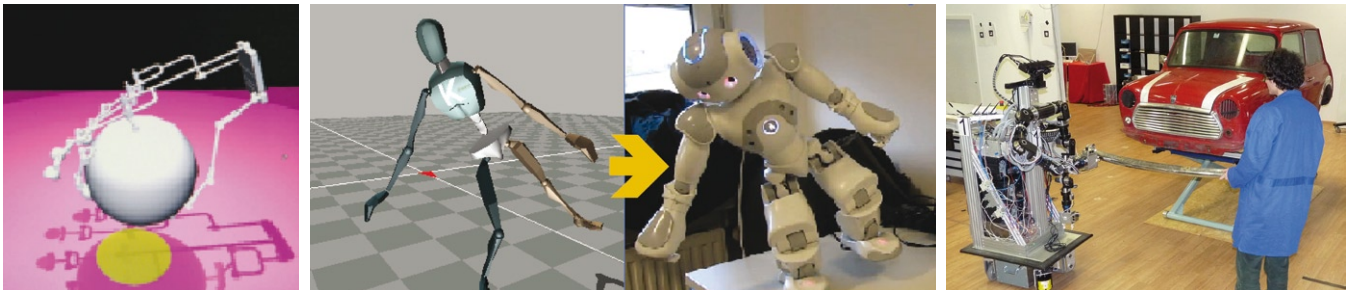

1 | Left: Autonomous execution of learned grasping skill. Middle: Whole body motion mapping from a human to a humanoid robot NAO. Right: Robot assistance for haptic cooperation.

First, the imitation learning approach was adopted for reaching and grasping. As a starting point of imitation learning of grasping skills, we built the mapping from a human hand to a robotic hand. Force and joint angle trajectories were captured during demonstrations performed by means of a teleoperation system. From successful demonstrations a series of grasp types were adopted/established, which could finally be executed autonomously by a robotic hand in a simulated environment even though the objects that were used differed in stiffness, mass or size.

We have developed a whole body motion mapping algorithm from a human to a humanoid robot with focus on dynamically stable robot locomotion motions including unstructured support stance changes. The method tries to preserve motion likeness as well as to enforce kinematic constraints such as singularities, joint limits, joint velocity limits, and self-collisions. However, the motion generated from the kinematic mapping may result in dynamically unstable motions performed by the humanoid robot due to dynamics differences. Therefore, dynamic mapping is adopted in order to manage the whole body dynamic balance and to imitate the foot stance of the human performer.

The well-known bipedal balance criterion ZMP (Zero Moment Point) and kinematic resolution of CoM (Center Of Mass) Jacobian are utilized for online balance control. The CoM motion pattern is generated online through an optimal preview controller based on the inverted pendulum model. In this manner, stance imitation is guaranteed to preserve dynamic balance and stable whole-body human motion imitation is achieved, as shown in the figure. Currently, we are extending this work to learning locomotion primitives and real-time walking imitation with the synchronization with the human performer, based on the prediction of future human movements.

Finally, we propose an incremental learning and prediction framework for an assistive controller in human-robot cooperative manipulation tasks. Instead of offline learning of manually segmented human motions and forces, the proposed method can learn human behaviors in an autonomous and incremental manner from an online unsegmented incoming data stream. As a consequence of the unsupervised incremental learning, the database of human behaviors is obtained and updated and the structures of primitives are represented by a primitive tree and a primitive graph. Based on this acquired knowledge, the system can predict the human future behaviors by utilizing a smooth motion generation technique which overcomes the discretized state space of hidden Markov models (HMMs). On a real-time control level, an admittance controller is used to adapt to the measured forces and, using the predicted trajectory as a reference trajectory, an impedance controller scheme is applied in order to assist the human on the execution of the task. The proposed concepts are implemented and evaluated using a mobile bi-manual platform (see the figure).

Selected Publications

- [1] K. Hu and D. Lee, "Prediction-based Synchronized Human Walking Motion Imitation by a Humanoid Robot," *Automatisierungstechnik*, vol. 60, no. 11, pp. 705–714, 2012.
- [2] J. R. Medina Hernández, D. Lee, S. Hirche, "Risk-Sensitive Optimal Feedback Control for Haptic Assistance," *IEEE International Conference on Robotics and Automation (ICRA)*, St. Paul, Minnesota, 2012, pp. 1025–1031.

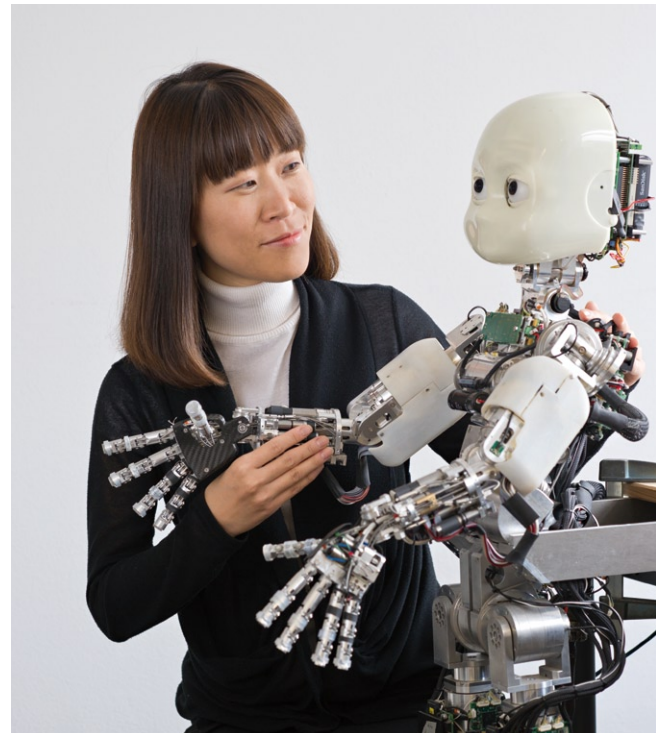

Dongheui Lee

has been an assistant professor at the Institute of Automatic Control Engineering since October 2009 and is the head of the Dynamic Human Robot Interaction for Automation System Lab. She received her B.S. and M.S. degree in mechanical engineering from Kyunghee University, Korea, in 2001 and 2003 respectively. She worked as a research scientist at the Advanced Robotics Research Center, Korea Institute of Science and Technology (KIST), from 2001 to 2004. In 2007, she received her doctoral degree from the University of Tokyo, Department of Mechano-Informatics, Japan. After having received her doctoral degree she joined the Center of Information and Robot Technology at the University of Tokyo as a project assistant professor. Her research interests include human motion understanding, human robot interaction, machine learning in robotics, and mobile robot navigation.

Haptic interaction and collaboration in human-human and human-robot dyads

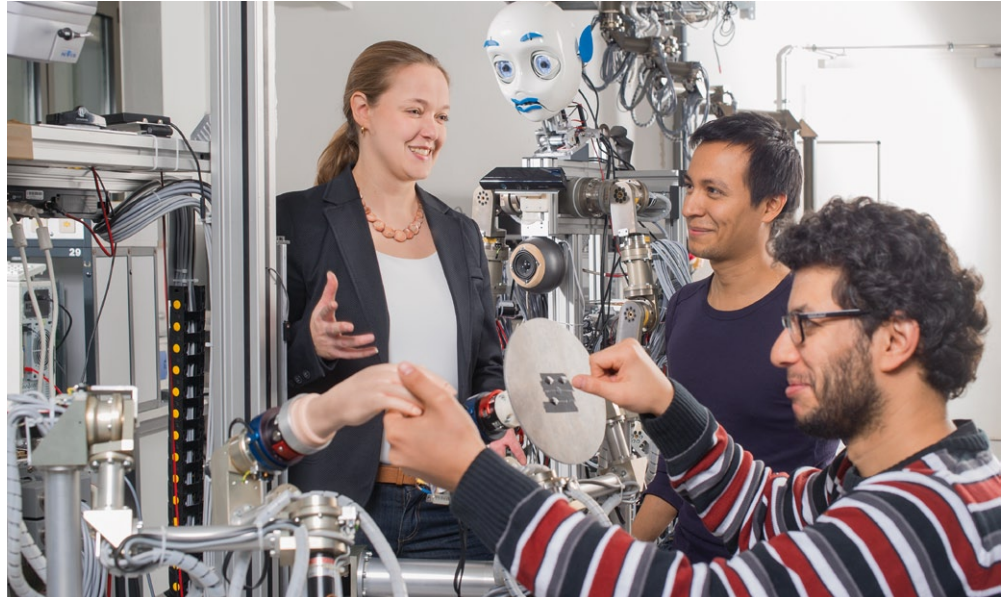

Touch is an indispensable component of interaction in real and virtual collaborative environments. Compared to other fields of interaction research like communication via speech and gestures, haptic interaction is still largely underrepresented. Doubtlessly, however, haptic interaction is an essential component for future robotic systems that are supposed to collaborate closely with humans in performing physical tasks as required when assisting in standing up, walking and sitting down or jointly transporting an object, when enhancing motor training and rehabilitation, or when socially interacting in form of a handshake or dance.

In many situations, people are not only expected to interact, but to collaborate, which means that both partners try to accomplish a common goal and therefore share intentions and action plans. Thus, haptic collaboration not only implies the physical coupling of two bodies either directly or via an intermediate object, but also involves higher-level cognitive processes. People have to negotiate their intentions and to coordinate their actions. The underlying principles of involved coordination and decision making processes, however, are largely unknown, which makes their implementation on a robotic platform challenging.

Thus, our approach undertakes to first analyze haptic coordination and decision making in human-human dyads and then to transfer gained knowledge to human-robot dyads. In doing so, special attention is paid to the investigation of typical role and strategy distributions adopted by partners and their evolution over time.

Adaptation is studied on several levels, from the adaptation of human arm stiffness to the adaptation of joint action plans. Intention estimation and negotiation are also considered important ingredients.

So far we identified behavioral changes when human partners act together compared to acting alone and found evidence that the interacting partners form strategies. Our technical implementations range from purely passive followers with varying impedance parameters as well as active robot partners that can estimate human intentions and based on them change their interaction behavior by taking over different roles.

Yet modeling attempts of haptic interaction so far mainly focus on replicating the input-output behavior, without gaining deeper insight in the underlying processes of haptic coordination and decision making. Thus, our future work will concentrate on joining efforts in modeling i) human movements based on theories of human motor control with efforts in modeling ii) higher-level processes involved in haptic coordination and joint decision making by incorporating and extending models researched in cognitive science.

Selected Publications

- [1] R. Groten, D. Feth, R. Klatzky, and A. Peer, "The role of haptic feedback for the integration of intentions in shared task execution," *IEEE Transactions on Haptics*, vol. 99, pp. 1939–1412, 2012.
- [2] J. Hölldampf, Z. Wang, A. Peer, and M. Buss, "Social haptic interaction with virtual characters," in *Immersive Multimodal Interactive Presence*, A. Peer and C. D. Giachritsis, Eds. London: Springer, 2012, pp. 189–214.
- [3] D. Feth, R. Groten, A. Peer, and M. Buss, "Haptic human-robot collaboration: Comparison of robot partner implementations in terms of human-likeness and task performance," *Presence: Teleoperators and Virtual Environments*, vol. 20, no. 2, 173–189, 2011.

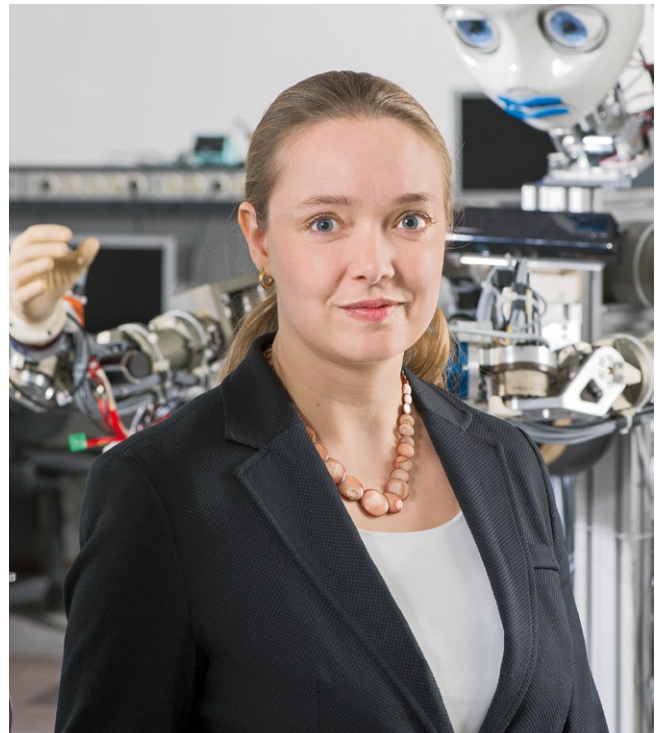

Angelika Peer

is currently a senior researcher and lecturer at the Institute of Automatic Control Engineering of the Technische Universität München and leader of a Junior Research group in the field of haptic interaction. She received her engineering degree in Electrical Engineering in 2004 and the Doctor of Engineering degree in Electrical Engineering in 2008 from the Technische Universität München. From 2004–2008 she was a research assistant at the Institute of Automatic Control Engineering of the same university. From 2007–2012 she was chair of the RAS Technical Committee on Telerobotics and is currently secretary of the Eurohaptics Society. Her research interests include robotics, haptics, teleoperation, human-human and human-robot interaction as well as human motor control.

Focus Group Molecular Imaging

Prof. Silvio Aime | Hans Fischer Senior Fellow

Giaime Rancan | Doctoral Candidate

© Prof. Markus Schwaiger, Clinic for Nuclear Medicine, TUM

28 New Fellows and their Research

Advances in MR – molecular imaging

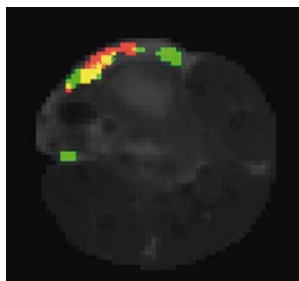

1 | MRI visualization of different cell types by means of CEST agents in a mouse.

In the past year 2012, our research work has achieved some important Proof of Concepts that may be relevant for the development of our future work in the field of Molecular Imaging (*in vivo* visualization of molecules or molecular events at cellular level).

The field of hyperpolarization continues to be a “hot topic” in MRI as it is considered to be one of the important routes to Molecular Imaging by this modality. The methodology that is most in use is represented by Dynamic Nuclear Polarization in which nuclei of the substrate of interest yield responses that are several orders of magnitude higher than the signal attained by thermal polarization. This is due to the irradiation of the EPR resonance of radicals (mixed in a solid solution with the substrate molecules) to which the NMR-active nuclei are dipolarly coupled. We have found that this process can be enhanced by a proper design of derivatives of the substrate of interest that is promptly generated when the hyperpolarized derivatives are dissolved in water. This approach significantly widens the number of molecules that can be considered for hyperpolarization.

The idea to work on derivatives that are more suitable for polarization procedures than the parent substrates has been extended to hyperpolarization procedures based on $p\text{-H}_2$. This approach relies on the fact that the addition of a molecule of $p\text{-H}_2$ to an unsaturated functionality (double or triple bond) generates a distribution of spins in the energy diagram that is markedly different from the thermal distribution. One may exploit this “abnormality” to generate hyperpolarized molecules. We have conjugated unsaturated $p\text{-H}_2$ reactive synthons on various substrates to generate hyperpolarized derivatives that mimic the endogeneous molecules.

Still, in the field of MRI, much attention has been devoted to the development of a new class of agents (CEST agents) that allow a multiplex visualization in the MR images. This task cannot be accomplished with the currently available MRI contrast agents that act on the relaxation times of water protons. The new class of contrast agents exploits the transfer of saturated magnetization to the water resonance (responsible for the contrast in the MR images) upon the selective irradiation of an exchangeable pool of protons on the CEST agent. This allows a frequency-encoding for each CEST agent whose presence in a given anatomical district can then be visualized by off-setting the irradiation frequency at the absorption frequency of the exchangeable pool of protons. By labeling different types of cells with different CEST agents we showed that these cells can be “tracked” *in vivo* (mice).

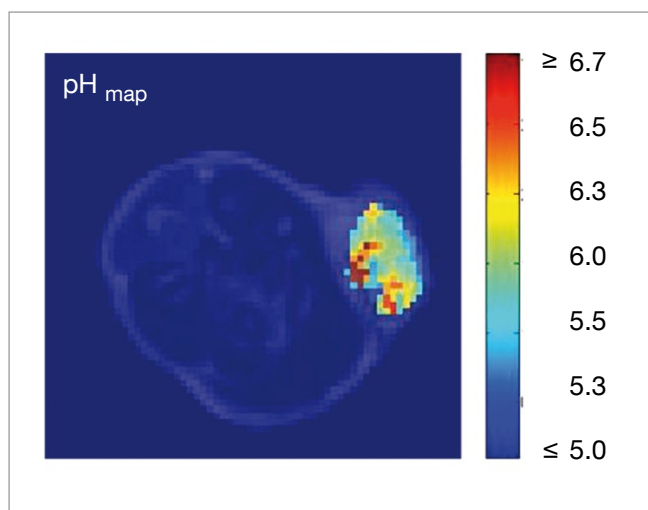

2 | MRI pH mapping in the tumor (melanoma) region (mouse).

Moreover, the frequency-encoding property of CEST agents allows the design of new classes of responsive agents, provided that two pools of exchanging protons are present on the same molecule. Our work in this field addressed the design of pH-responsive CEST agents. Among a number of investigated systems, it has been found that Yb-HPDO3A is an excellent candidate for *in vivo* pH mapping with the MRI modality. This molecule is strictly analogous to Gd-HPDO3A which is extensively used in the clinical practice as MRI relaxation agent. Therefore, we think that this analogy may make the translation procedure for Yb-HPDO3A easier once it will have been proved that mapping pH provides important insights to the clinician both in terms of early diagnosis and in monitoring the follow-up of the undertaken therapy.

Selected Publications

- [1] G. Ferrauto, D. D. Castelli, E. Terreno, and S. Aime, "In vivo MRI visualization of different cell populations labeled with PARACEST agents," *Magn. Reson. Med.*, Jul. 2012. doi: 10.1002/mrm.24411.
- [2] F. Reineri, A. Viale, S. Ellena, D. Alberti, T. Boi, G. B. Giovenzana, R. Gobetto, S. S. Premkumar, and S. Aime, "15N magnetic resonance hyperpolarization via the reaction of parahydrogen with 15N-propargylcholine," *J. Am. Chem. Soc.*, vol. 134, no. 27, pp. 11146–52, 2012.



Silvio Aime

graduated from the University of Turin in 1971. After a stint at the University of East Anglia, he returned to Turin in 1974 where he spent his entire career. He is currently Professor of General and Inorganic Chemistry at the Department of Molecular Biotechnologies and Health Sciences and Head of the Center for Molecular Imaging of the University of Turin. Professor Aime's main research is focused on developing diagnostic agents containing lanthanides or hyperpolarized molecules for applications of magnetic resonance imaging with a particular interest in molecular imaging procedures.

Predicting complex traits in plants, animals and humans

Agricultural and human genetics are currently revolutionized by the technological developments in genomic research. High-throughput genotyping technology delivers hundreds of thousands of single nucleotide polymorphism markers and has become available for many crops, livestock species and humans. The genomes of a large number of individuals can now be analyzed for their specific marker profile at high density. The technological feasibility of obtaining full genome sequences at reasonable costs for a large number of individuals is within striking distance. Thus, the genetic analysis of quantitatively inherited traits and the prediction of the genetic predisposition of individuals based on molecular data are rapidly evolving fields of research in medical and agricultural genetics.

$$E(\hat{\beta}) = \begin{bmatrix} \mathbf{x}'_1 \mathbf{x}_1 & \mathbf{x}'_1 \mathbf{x}_2 & \dots & \mathbf{x}'_1 \mathbf{x}_p \\ \cdot & \mathbf{x}'_2 \mathbf{x}_2 & \dots & \mathbf{x}'_2 \mathbf{x}_p \\ \cdot & \cdot & \dots & \cdot \\ \cdot & \cdot & \dots & \cdot \\ \cdot & \cdot & \dots & \cdot \\ \text{symmetric} & \cdot & \dots & \mathbf{x}'_p \mathbf{x}_p \end{bmatrix}^{-1} \begin{bmatrix} \mathbf{x}'_1 (\mathbf{q}_1 \alpha_1 + \mathbf{q}_2 \alpha_2 + \mathbf{q}_{12} \alpha_{12}) \\ \mathbf{x}'_2 (\mathbf{q}_1 \alpha_1 + \mathbf{q}_2 \alpha_2 + \mathbf{q}_{12} \alpha_{12}) \\ \cdot \\ \cdot \\ \cdot \\ \mathbf{x}'_p (\mathbf{q}_1 \alpha_1 + \mathbf{q}_2 \alpha_2 + \mathbf{q}_{12} \alpha_{12}) \end{bmatrix}$$

1 | Single marker genome-wide association studies are based on regressions of an outcome on a single marker. The slide shows that, even when p markers are fitted in the model, there is a bias that depends on: linkage disequilibrium among the p markers (first matrix to the right of the equality sign),

linkage disequilibrium between the p markers and the unknown quantitative trait loci (QTL), and unknown effects of these QTL. The slide shows two epistatic QTL, with the α 's denoting the effects of the two QTL and of their interaction. (Gianola, D. Course "Statistical methods for genome-enabled selection". TUM-IAS, September 8-12, 2012)

Prof. Gianola and his hosting Focus Group develop a methodology that allows prediction of complex traits in plant and animal breeding and in human or veterinary medicine using genomic information and statistical learning techniques. Relevant statistical models must account for the high-dimensional nature of the available genomic information as well as high genome complexity of the species under study. Massive amounts of data derived from next generation sequencing, high-throughput genotyping, and large scale phenotyping need to be integrated.

The Focus Group uses Bayesian models as well as semi-parametric and machine learning procedures to account for the fact that the system is more than the sum of individual effects. In particular, reproducing kernel Hilbert spaces regression procedures and neural networks will be tested for their prediction performance using large scale experimental data from maize, chicken and cattle in collaboration with the interdisciplinary network of excellence in agricultural research “Synbreed”. The statistical methods developed within the context of plant and animal breeding are currently also entering the field of human genetics. As a next step, the Group will intensify its collaboration with colleagues from medicine to investigate if the statistical methods developed in plant and animal genetics will also be applicable to the prediction of genetic predisposition in humans.

During his visits at TUM in 2012, Prof. Gianola contributed to a paper dealing with the influence of prior distributions on inference and predictive ability for plant traits. The paper has recently been accepted for publishing in „Statistical Applications in Genetics and Molecular Biology“. In collaboration with the cluster “Synbreed”, Prof. Gianola intensively discussed on-going work with doctoral candidates and offered a one-week course entitled „Statistical methods for genome-enabled selection.“

Selected Publication

- [1] C. Lehermeier, V. Wimmer, T. Albrecht, H.J. Auinger, D. Gianola, V. Schmid, and C.C. Schön, “Sensitivity to Prior Specification in Bayesian Genome-based Prediction Models,” *Statistical Applications in Genetics and Molecular Biology*, accepted.

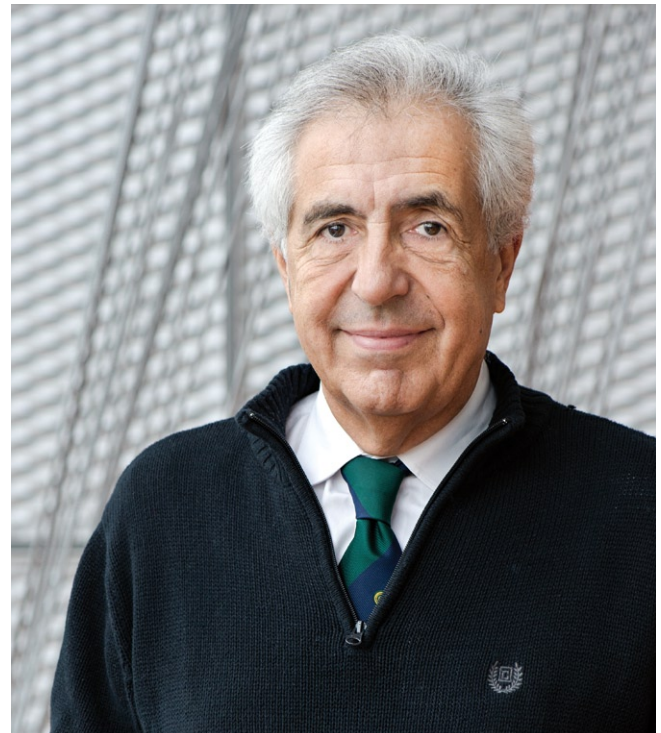

Daniel Gianola

obtained his Ing. Agr. Degree in Agriculture and Animal Production from the Universidad de la Republica in Uruguay, and his MSc and PhD in Animal Breeding and Statistics from the University of Wisconsin-Madison. Between 1971 and 1975 he held research assistant positions at Cornell University (Animal Science) and at the University of Wisconsin (Medical Genetics). After a few years with the World Bank, he eventually became a full professor at the University of Illinois at Urbana-Champaign. Currently he holds a Sewall Wright professorship in the Department of Animal Sciences at the University of Wisconsin, with joint appointments in the Dairy Science and Biostatistics and Medical Informatics departments, where he has been in the faculty since 1991. He has held a considerable number of visiting professorships in prestigious universities all over the world, and has developed consulting activities for several research institutions, as well as for international organizations (e.g., the World Bank and USAID). He has received six honorary doctorates and many national and international awards, such as the Alexander von Humboldt Senior Research Award.

Highlights and Achievements

World Development and Ecology

Systems, Design and Control

New Computing Paradigms

Cells, Molecules and Biomedical Engineering

Nanoscience

Fundamentals of Science and Technology

TÜV Süd Stiftung Visiting Professors





In this section, TUM-IAS Focus Groups report on their proceedings and successes in 2012 (up to now we mostly do not report failures, although that might be just as interesting from a scientific point of view). TUM-IAS greatly honors the freedom and initiative of its Fellows and the Focus Groups that host them - real innovation in science cannot be ordained - it also trusts their good judgment as to where they let their thoughts and experiments go. However, from their reporting and the many contacts our Fellows have, some major thematic “lines of force” appear which for this annual report we use as ordering principle on the contributions. Needless to say, themes influence each other, science (and technology) form a fabric of interwoven principles (the warp) and application domains (the weft), which are often hard to tell apart and together form the great variety of patterns an institute like ours can show to the outside world. We start our account from (extra) large, gradually moving to (incredibly) small.

World Development and Ecology

Starting from interest in our global world and how its ecology can be faithfully documented over centuries from subtle biological traces in our Focus Group “Global Change,” we move to challenges in architecture and civil engineering with “Metropolis Nonformal” in which people-friendly transformation of slums into livable areas are conceived, and then further to the creation of new types of building materials (in particular new concrete) with much better properties through “Advanced Construction Chemicals and Materials,” to assessing environmental risks in (sometimes large) developmental projects. In all these cases, statistical analysis plays a fundamental role, and the Institute has seen great interplay of these Focus Groups with our former Focus Group on “Risk Analysis and Stochastic Modeling” for mathematical support. In a different, more analytically oriented direction, the Focus Group “Soil Architecture” studies the intimate physical, chemical and biological properties of our ubiquitous soil, with the purpose of improving its usage, e.g. as a repository of carbon.

Systems, Design and Control

Engineers are designers. Not only do they reflect on design in its various aspects, they also design real things, and in our case very innovative ones. Realizing that the world will soon be going almost fully electrical, and following the pioneering example of the Munich engineer Rudolf Diesel, the Focus Group “Diesel Reloaded” is not only designing, but also at least conceptually realizing a new electrical future for mobility in its various aspects, not the least of one being intelligent autonomous driving. The new brave electrical world that is rashly being developed does not only need a new type of mobility, but also a new, much more distributed and locally controlled hence much more intelligent smart grid, the topic of our Focus Group “Networked Dynamical Systems”.

Fully error-free control of super fast aircraft, using modern control technology is at issue in the Focus Group “Aircraft Stability and Control”. There are strong interactions between these concrete design efforts and the large research and development effort at TUM and TUM-IAS on “Cognitive Technology” in general and in particular robotics. Here, fundamental problems such as understanding the working of abstractions, the inclusion of human intelligence in a control loop, learning methods and intelligent use of sensing are investigated, but the results are immediately put into robotic practice, testing the new concepts by ‘eating the pudding’. The development of pure design methodology is covered by the Focus Group of Prof. Matthew Campbell on advanced mechanical design technology with new ideas on design representation and semantics.

New Computing Paradigms

The extreme versatility of computers as modeling and visualization instruments provides plenty of room for original and incredibly useful but fundamental research. Not surprisingly, modeling and evaluating parts of the human body has been a prime target of numerically keen analysts. Our Focus Group “Advanced Cardiac Mechanics Emulator” targets the human heart and the flows therein, while “Computational Biomechanics” models healthy and sick bones as well as bones with prostheses, and provides bone surgeons with invaluable data on their strength. Also other fields with ‘multiphysics’ or multidimensional environments offer plenty modeling challenges to our “High-Performance Computing” and “Advanced Stability Analysis” Focus Groups, the first combining structural analysis with flows, and the second modeling the coupling between acoustics and plasmas. All these groups are engaged in sophisticated discretization methods, but the Focus Group of Prof. Peter Schröder on advanced geometric modeling has taken the geometric basis for discretization as its core business.

Cells, Molecules and Biomedical Engineering

The multi-cellular world may look very complex, but a cell provides probably the mini-universe of highest possible complexity. To honor this feat, but also to reach the heart of this most ubiquitous constituent of nature and ourselves, two Focus Groups are directly investigating cellular properties, our “Neuroscience” group concentrating on the properties of neurons, and our “Clinical Cell Processing and Purification” group on the therapeutic use of the immunological properties of improved T-cells. Going to smaller dimensions, several types of molecules can be engineered to achieve new tasks, the “Biochemistry” Focus Group has been concentrating on the synthesis of new types of bio-molecules e.g. on the basis of a peptide scaffold, and our pretty large Focus Group “Biophysics” on the design and realization of completely new systems, merging the properties of DNA and MEMS technology to create novel functional molecular systems, from origami to nano-bots. Small goes together with big instrumentation and the Focus Groups on “Biomedical Engineering” and “Molecular Imaging” have been developing new MRI-based instrumentation to have a closer look at structures from the molecular level all the way to multi-modal MRI-PET scans of patients (some equipment even portable!)

Nanoscience

The large array of efforts in our Institute to master nature in the nano ‘regime’ already visible in the previous section is further complemented with Focus Groups concentrating on various types of structures and devices at the nano scale level, quantum materials and the necessary technology to make the newly conceived devices practical, even up to an industrial level. An intimate link with the previous area on molecular engineering is provided by the Focus Group “Molecular Aspects of Interface Science,” which is very actively developing the nano structures needed for the chemically active electrodes of our future batteries and fuel cells, a field of great interest for our future electrical mobility. The Focus Group “Nanophotonics” is developing new nano-technology for photonic devices (such as lasers) on a silicon platform, using the properties of III-V nanostructures and hetero nanowires to be combined with optical guidance based on artificial 3D crystals, and/or arrays of nanowires. The Focus Group “Nanoscale Control of Quantum Materials” interests itself in the behavior of molecules on surfaces, with the goal of tuning the functionality of single molecules and promoting the self-assembly of supra-molecular architectures. At an engineering level, the Focus Group “Nanoimprint and Nanotransfer” has demonstrated that entire functional nanometer scale devices can be produced economically with nanoimprint and nanotransfer techniques, including novel nanomagnetic logic, a strong transatlantic research collaboration pioneered by this Focus Group (sponsored by DARPA as well).

Fundamentals of Science and Technology

This account could have started with fundamentals, as all serious technology has its fundamental underpinnings, but here we put our fundamental research as a culmination of our efforts to gain ever deeper and better understanding of nature. As telecommunication is now handling in the order of 100 Peta-Bytes (if not more) of data hourly, the need for fast, massive communication is greater than ever, especially since the limits of classical fiber communication are being reached presently. A good reason to study non-linear phenomena in “Fiber-Optic Communication and Information Theory” again! This fundamental study in Electrical Engineering turns up a Schrödinger equation in a new habitat. Our Focus Group on “Nonequilibrium Statistical Mechanics at the Nanoscale” has produced a remarkable and surprising result: a universal but very concrete description of the generic cellular automaton, covering all potential cases in a systematic way and allowing the biomimetic replication of artificial organisms. The crown on our fundamental work is finally provided by our Focus Group “Fundamental Physics” whose original theory of flavor physics provides a further basis of development of the standard model of particle physics, in which the (maybe) newly discovered Higgs boson forms an important new ingredient. Finding the truth in this area requires a close interplay between theory that formulates potential effects and experiments that verify whether the predictions hold, and hence a group of researchers standing on the breach of developments.

TUM-IAS can be proud of all this teaming scientific production, but let the Focus Groups speak for themselves!

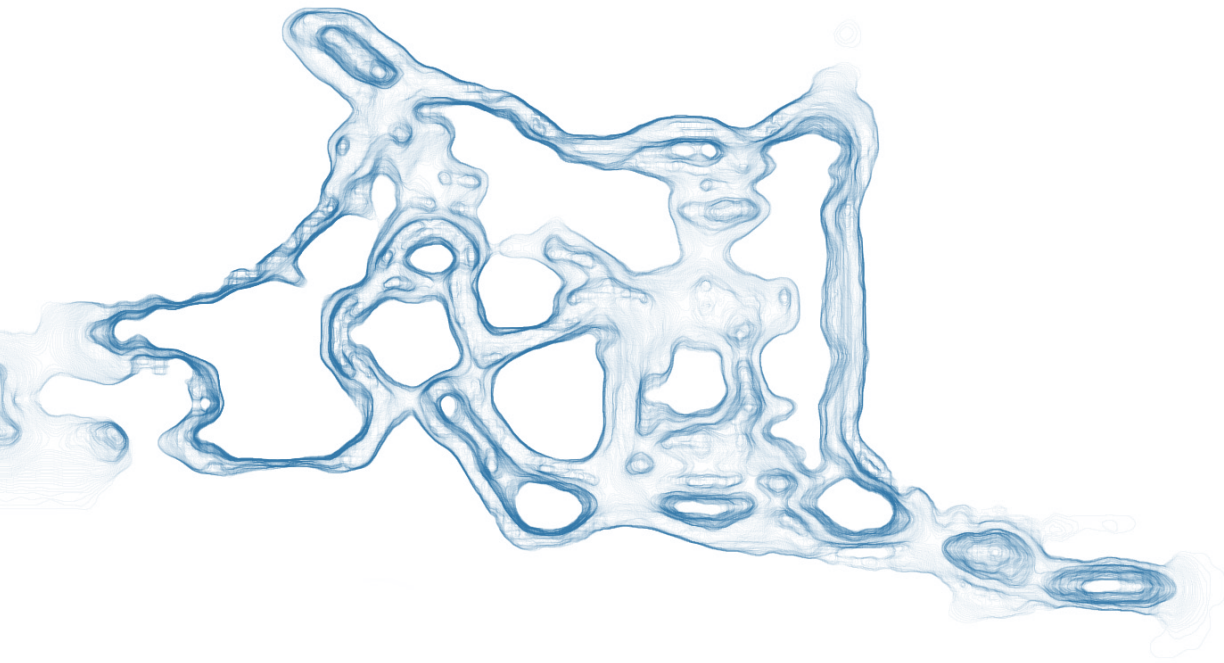

Advanced Construction Chemicals and Materials

Metropolis Nonformal

Soil Architecture

Global Change

Focus Group **Advanced Construction Chemicals and Materials**

Dr. Tsuyoshi Hirata | Rudolf Diesel Industry Fellow

Alex Lange | Doctoral Candidate

© Prof. Johann Plank, Construction Chemicals, TUM

40 Highlights and Achievements



Tsuyoshi Hirata

Working mechanism of polycarboxylate-based superplasticizers for concrete

The TUM-IAS Advanced Construction Chemicals and Materials Focus Group, involving Dr. Tsuyoshi Hirata, Prof. Johann Plank and the doctoral candidate Alex Lange, focuses on the working mechanism of polycarboxylate-based superplasticizers with polyethylene glycol pendants (PCEs) using methods from colloid chemistry.

PCEs enable the concrete to fluidize with extremely small quantities of water due to their excellent dispersing force. Hence PCEs play an important role in supplying high-durability concrete such as ultra-high strength concrete, self-compacting concrete and so on. PCEs adsorb onto the surface of cement particles by carboxyl groups from the polymer main chain. Furthermore, they disperse the cement particles through steric repulsion via PEG side chains. We aim to clarify the working mechanisms of PCEs from the viewpoints of nano-chemistry: one is the conformation of the PCE molecule before and after adsorption onto the cement surface, and the other is how such a PCE molecule interacts with cement hydrates which form immediately after the cement comes in contact with water.

Another goal is to identify the most efficient PCE structure for different cement compositions and to understand their working mechanism: first of all, the enhancement of the water-reducing rate, second is the adaptation to any variation in cement composition and the third is the improvement of concrete viscosity at very low water content. The latter is to reduce the sticky consistency of e.g. ultra-high strength concrete. The water-like fluidity is defined as “Saratto-kan” fluidity in Japan.

In the last report in 2011, we explained that the conformation of a PCE molecule changes in cement pore solution and when adsorbed on the surface of cement, depending on the difference in main and side chain structures. Consequently, a star-like PCE with long PEG side chains was most effective at low dosage.

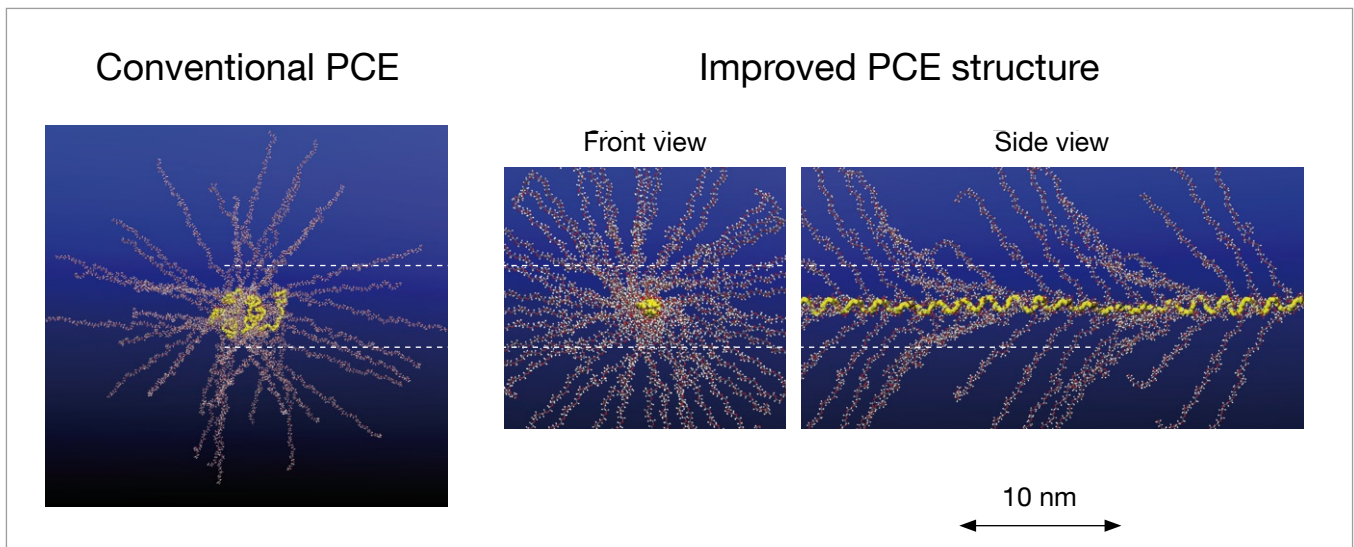

1 | Schematic diagrams of the molecular conformations of a conventional and of the newly developed PCE by molecular dynamics; Amorphous Cell module; Accelrys Software Inc.

During the past year we found that the adsorbed layer thickness (ALT) of PCE on the cement surface is responsible for a low dosage, showing the thickest ALT for star-like PCEs. Furthermore, we discovered that specific cement constituents (C_3A , CaO) increase the PCE dosage. However, a newly developed PCE with a rigid main chain does not show this undesired effect. This PCE exhibits a rod-like conformation, as can be seen in figure 1, compared to conventional PCEs which display a spherical shape. It seems that such shape is advantageous for improved cement compatibility. The next goal is to clarify why this PCE is not influenced by some cement constituents or cement hydrates.

From this study it was learnt that the Saratto-kan effect can be obtained from very hydrophilic PCE molecules such as the newly composed PCE. There, a specific ratio between the hydrophilic and lipophilic balance in the molecule (HLB value) plays a key role. The authors wish to express their gratitude to TUM-IAS for its generous support of this fascinating research project.

Patent

- [1] T. Hirata, A. Lange, J. Plank "Copolymer for Dispersant for Cement, Dispersant for Cement, and Cement Composition", EP 12162379.7, applied on March 30, 2012.

Focus Group Metropolis Nonformal

Prof. Christian Werthmann | Hans Fischer Senior Fellow

Gokce Iyicil | Doctoral Candidate

© Prof. Regine Keller, Landscape Architecture and Public Space, TUM

42 Highlights and Achievements



Christian Werthmann



1 | Onaville area in Port-au-Prince

Metropolis nonformal

Over the last hundred years non-formal urban growth has greatly increased and accounts for about one third of our urban population. For the coming decades it is predicted that the migration from rural to urban will continue at least until 2050, especially in the Global South. UN-data indicates that future migrants will continue to build complete cities indifferent to urban planning schemes. Self-construction will occur on an unprecedented scale, measuring three billion city dwellers over the next 40 years. Thus non-formal cities will constitute not only close to half of our urban growth on this planet, but will house the majority of our young urban population. While the populations of the highly industrialized countries of the Global North will continue to stagnate or shrink, the majority of population growth will happen in little industrialized or in rapidly industrializing regions of the world.



2 | A water cistern in use in Onaville

My activities as a Hans Fischer Senior Fellow have concentrated on the potential response and involvement of designers, planners and engineers of highly industrialized countries such as Germany regarding the phenomenon of informal urbanization. My focus is on the insertion of socio-ecologic sensitive infrastructure into non-formal settlements. In my first year of the Fellowship in 2011, I started to form collaborations with the Chair of Landscape Architecture and Public Space, Prof. Regine Keller, and the Institute of Water Quality Control, Prof. Harald Horn, and his interim successor, Prof. Brigitte Helmreich, to develop landscape based water management strategies in the current reconstruction efforts of Port-au-Prince, Haiti. In 2011, a group of six students (three environmental engineers and three landscape architects) completed a studio project in a floodplain of Port-au-Prince that is under heavy urbanization pressure. One landscape architecture master student (Florian Strauss) accompanied me on a visit there and completed his master thesis in 2012 under the supervision of Thomas Hauck and myself. Just recently we were delighted to learn that Florian Strauss' Master Thesis "Terra Nova Ayiti" won the prestigious Zvi Miller Award of the International Federation of Landscape Architects as the second best entry in the student project category worldwide.



3 | Digging of new water well in Onaville with collaboration of UN-MINUSTAH, UNASUR and TECHO



4 | Community meeting in Onaville conducted by TECHO

Furthermore, 2012 saw a continuation and deepening of the initiatives started at the beginning of my Fellowship. In 2011, Gokce Iyicil, doctoral candidate of environmental engineering, began to formulate her thesis work under the supervision of Prof. Helmreich and myself. In 2012, with the help of the TUM-IAS and the Chilean NGO “UN Techo Para Mi Pais”, Gokce Iyicil could visit the emergency settlement of Canaan where she performed two weeks of field-work to develop an integrated water management scheme. Canaan is a hillside community 10 km from the center of Port-au-Prince. After the 2010 earthquake over 30,000 refugees started to build tents and houses without any infrastructure in this dry and erosion prone hillside. Inside Canaan, Gokce Iyicil studied an exemplary neighborhood of roughly 3,000 inhabitants.

Her work concentrates on the provision of potable water, sanitation and storm water management as one integrated system. Since her return to Munich Gokce Iyicil has been overseeing the work of several environmental engineering students and began to collaborate with master students from the landscape architecture program under the supervision of Thomas Hauck and Regine Keller. Their common vision is to develop holistic water and public space improvements for the rapidly growing settlement.

I also continued with my efforts to convene outstanding scholars on the topic of informal urbanism. Back in fall 2011, I invited nine professionals and academics who performed exemplary improvements in non-formal settlements to Munich. They gave a presentation at the symposium *Metropolis Nonformal*. For fall 2013, in my last year of my Fellowship, I plan to do a follow-up event with a focus on anticipatory approaches that can manage future informal construction activity. This symposium will be co-coordinated with UN-Habitat as part of a wider initiative to bring together scholars and doctoral candidates whose interests align on non-formal urbanism.

Selected Publications

- [1] C. Werthmann, “Is Informal Urbanism Sustainable,” in *Sustainable Urbanism and Beyond*, T. Hassan, Ed. New York: Rizzoli, 2012.
- [2] C. Werthmann, “Biotic Rooftops,” in *Ecological Architecture*, T. Schroeffer Ed. Basel: Birkhaeuser, 2012.

Focus Group Soil Architecture

Prof. Ingrid Kögel-Knabner | Carl von Linde Senior Fellow

Dr. Geertje Pronk | Postdoctoral Researcher

© Soil Science, TUM

44 Highlights and Achievements



Ingrid Kögel-Knabner

Aggregate formation in artificial soils

Microscale studies on soil (micro-)aggregates and the biogeochemical interfaces associated with them have been identified as an emerging interdisciplinary challenge in soil science. A crucial prerequisite for the understanding of processes occurring at this spatial domain is to elucidate the mineral-organic composition, the spatial arrangement of the constituents including the hierarchical structure and architecture of the aggregate system and the corresponding pore network, and, finally, the role of the microbial communities forming and acting at the aggregate system and the biogeochemical interfaces. The NanoSIMS soil analytical tool developed in our group allows for the analysis of the compositional heterogeneity and architecture of the aggregate system and the corresponding biogeochemical interfaces.

In a new experiment, 'artificial soils' were produced by incubation of pure minerals, organic matter and a microbial inoculum from a natural soil. The complexity of the C stabilization process was reduced to formation of organo-mineral associations and aggregates through microbial products interacting with mineral components with known composition and initial properties. Macroaggregates were formed quickly, but aggregation declined as the OM was gradually decomposed, whereas organo-mineral associations formed gradually and continued to increase until the end of the experiment. The turnover of macroaggregates and continuing formation of organo-mineral associations through the total incubation time of 18 months was consistent with an aggregate hierarchy model.

The results from this experiment show that there are redundant mechanisms of aggregate formation in soils, depending on the presence or absence of mineral materials. These aggregates are formed during the decomposition of the organic substrate by a microbial community that differentiates during incubation in dependence of the mineral composition. Our experimental approach offers a valuable model where the formation and interactions of soil properties and processes can be studied in a well-defined system.

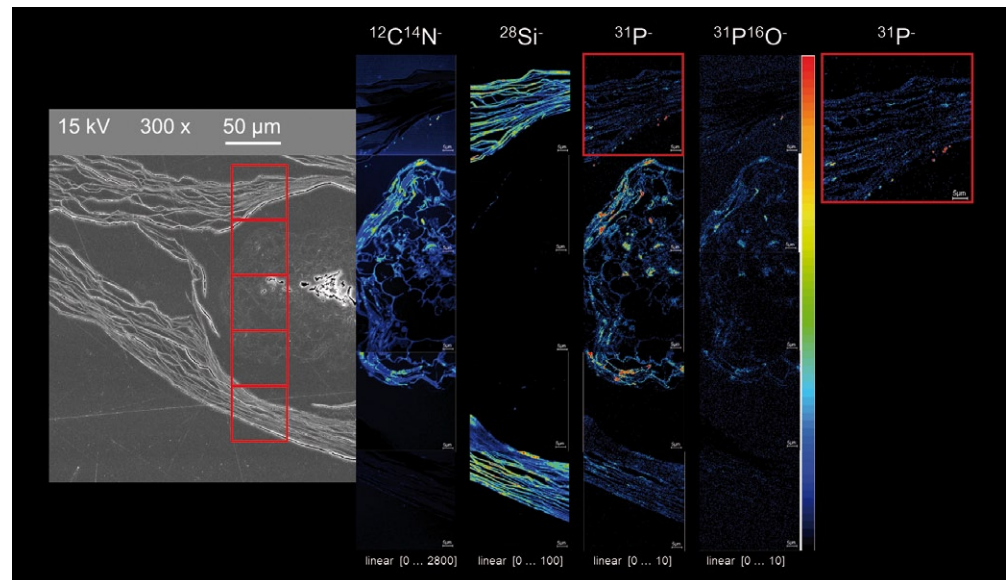

1 | Back scattered electron image and NanoSIMS images ($^{12}\text{C}^{14}\text{N}^-$, $^{28}\text{Si}^-$, $^{31}\text{P}^-$ and $^{31}\text{P}^{16}\text{O}^-$) of an embedded cross section of a root (*Quercus robur*) grown in a mixture of vermiculite and soil. The row of red squares indicates the positions analysed by NanoSIMS ($50 \times 50 \mu\text{m}$). The hue scale indicates the counts per second and pixel of the secondary ions collected. All NanoSIMS images are in linear scale, and the values in parentheses specify the range of detected counts per pixel for each secondary ion. The uppermost image of $^{31}\text{P}^-$ is enlarged at the right for clarity.

Selected Publications

- [1] G.J. Pronk, K. Heister, G.-C. Ding, K. Smalla, and I. Kögel-Knabner, "Development of biogeochemical interfaces in an artificial soil incubation experiment; aggregation and formation of organo-mineral associations," *Geoderma*, vol. 189–190, pp. 585–594, 2012.
- [2] K. Heister, C. Höschen, G.J. Pronk, C.W. Mueller, and I. Kögel-Knabner, "NanoSIMS as a tool for characterizing soil model compounds and organo-mineral associations in artificial soils," *Journal of Soils and Sediments*, vol. 12, pp. 35–47, 2012.

Focus Group Global Change

Prof. Tim Sparks | Hans Fischer Senior Fellow

Anna Bock, Julia Laube | Doctoral Candidates

Dr. Nicole Estrella, Dr. Susanne Jochner, Dr. Christian Zang | Postdoct. Researchers

© Prof. Annette Menzel, Ecoclimatology, TUM

46 Highlights and Achievements



Tim Sparks

Investigations into long-term changes in plants

Many of the trees that line the streets of Europe's major cities are the pollution-tolerant species *Platanus × acerifolia*, known in the UK as the London Plane. Consequently, they often feature in the backdrop of many photographs, particularly on ceremonial occasions.

Photographs taken on London's Whitehall since 1919 on November 11, Remembrance Day, allow us to study how the fall of leaves has changed over the last 90 years or so. In the 1920s and 1930s it was quite common for these trees to have lost all their leaves by this date, but in recent years this has not happened and trees often remain resolutely green. Such novel sources of data extend the scant information we have about changes in the timing of autumn.



1 | Plane trees on London's Whitehall

Both our doctoral candidates were very busy in 2012. Anna Bock ventured beyond her vineyard data to interrogate more than 110,000 dates of haymaking in Germany recorded since 1951. She presented these results at the "Phenology 2012" conference in Milwaukee, USA. Developments from that conference include a possible collaboration with Finnish researchers and a visit to Australia. Furthermore, a unique collection of flowering dates of plants from the island of Guernsey required more than 285 hours of data input, and the quality control and analysis of these data will keep her busy well into 2013. Meanwhile, Julia Laube was completing several experiments on the triggers for tree leafing in spring and on the competitiveness of alien plant species. Her leafing results were presented in two conference papers at "Phenology 2012". These had to be given by each of her supervisors since Julia Laube was simultaneously presenting at a separate conference on alien plant species in Spain!

The focus group also contributed to a major paper on changes in the timing of pollen across Europe [1]. This paper highlighted, in particular, increases in the amount of allergenic pollen in Europe. Reported increases were greater in urban than in rural environments. Thus, the consequences for human health could be very serious. In a separate paper on Birch pollen [2] we hypothesize that the timing of this early species may be approaching its limit in the UK. In 2013 we intend to devote more time to investigating limits to the advancement of phenology.

Selected Publications

[1] C. Ziello et al., "Changes to airborne pollen counts across Europe," *PLoS One*, vol. 7, no. 4, e34076, 2012.

[2] R. M. Newnham, T. H. Sparks, C. A. Skjøth, K. Head, B. Adams-Groom and M. Smith, "Pollen season and climate: Is the timing of birch pollen release in the UK approaching its limit?" *International Journal of Biometeorology*, 2012. doi: 10.1007/s00484-012-0563-5.

Advanced Computation

Aircraft Stability and Control

Cognitive Technology

Networked Dynamical Systems

Diesel Reloaded

Focus Group **Advanced Computation**

Prof. Matthew Campbell | Hans Fischer Senior Fellow

Amir Hooshmand | Doctoral Candidate

© Product Development, TUM

48 Highlights and Achievements



Matthew Campbell

Automatically generated designs through generative grammars

In engineering design, complex analyses (such as FE, CFD and thermal analysis) are required for calculating the engineering behavior of generated designs. Automatically integrating these analyses is a known challenge in the development of future computational tools that automatically create solutions. During the last 22 months, Prof. Matthew Campbell's Focus Group has developed a platform to facilitate generative design systems in achieving more flexible design synthesis automation and optimization. This enables the scientist to explore the abilities of generative design systems rather than coping with complexities of automatically integrating these analyses in the design process. The developed platform uses several reputable open-source software packages to perform multi-physics simulations. The modular nature of the platform provides a powerful foundation for scientists building specialized tools – just as Prof. Campbell's team uses the tools to automatically synthesize challenging mechanical engineering problems as is described next.

Optimization of fluid channels is an essential topic in designing microfluidic devices. It has application in diverse areas such as designing diffusers, valves, interior air flow of vehicles, and engine intake ports. Using topology optimization methods in solving channel fluid layouts has received a large amount of attention in recent years. However, even very recent results show that problems are mainly limited in complexity; number and direction of inlets and outlets, flow equation, and number of fluid types. They are mainly 2D problems and the lengthy computational time is still a challenge, especially for solving complex 3D problems. Campbell's Focus Group has introduced a new perspective through their graph grammar generative design approach. In this approach different topological (the manner in which inputs connect to outputs) solutions are first generated. This is followed by a number of grammar rules that include heuristics to smooth out the path and ensure smooth transitions in the diameters. The candidate graph is then transformed into 3D shapes which are simulated within the platform described above. The effectiveness of the proposed method is checked not only by comparing the performance on a variety of benchmark problems found in the literature (Campbell's results appear to be 20 to 50 times faster), but by solving different complex problems with arbitrary flow directions (figure 1).

The second (ongoing) research project is to find near-optimal shapes and topologies of trusses for given boundary conditions and loads. Like the fluid channel problem, a graph grammar interpreter is used to generate various truss topologies. The best candidates are selected on the basis of criteria such as cost, stiffness, and stress and are limited to actual truss building materials (figure 1).

Selected Publications

- [1] A. Hooshmand and M. I. Campbell, "Topology Optimization of Fluid Channels Using Generative Graph Grammars," submitted for publication.
- [2] A. Hooshmand, L. Balaus, M. Schlaich and M. I. Campbell, "CDS Platform - a Platform for Multi-Physics Computational Design Synthesis," submitted for publication.

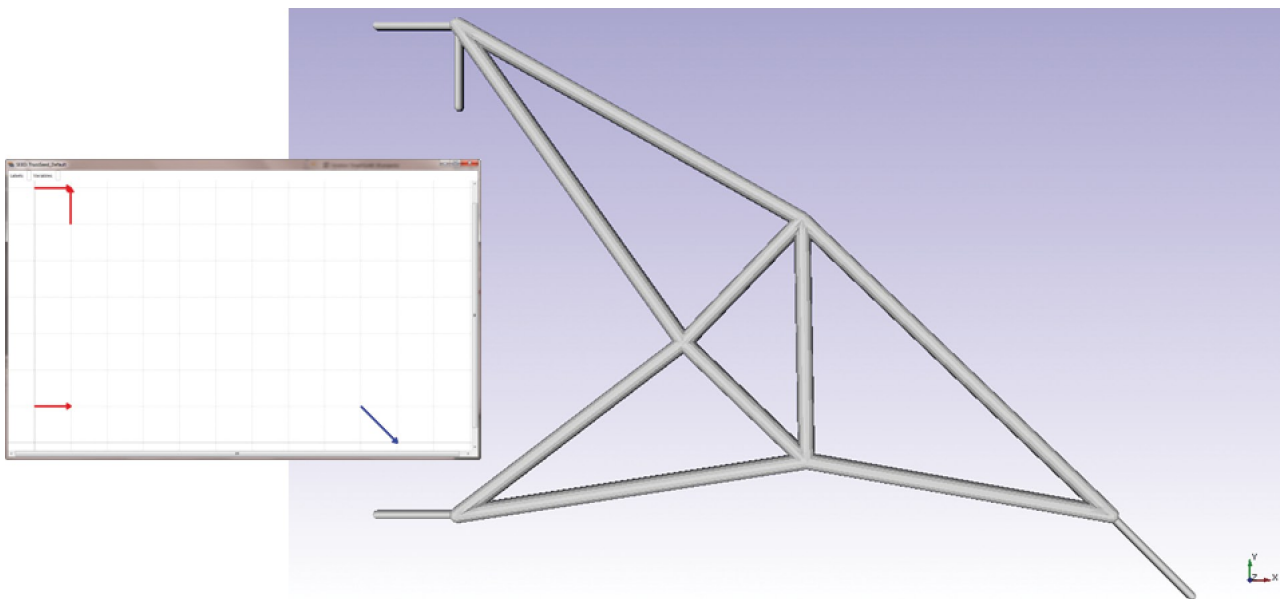
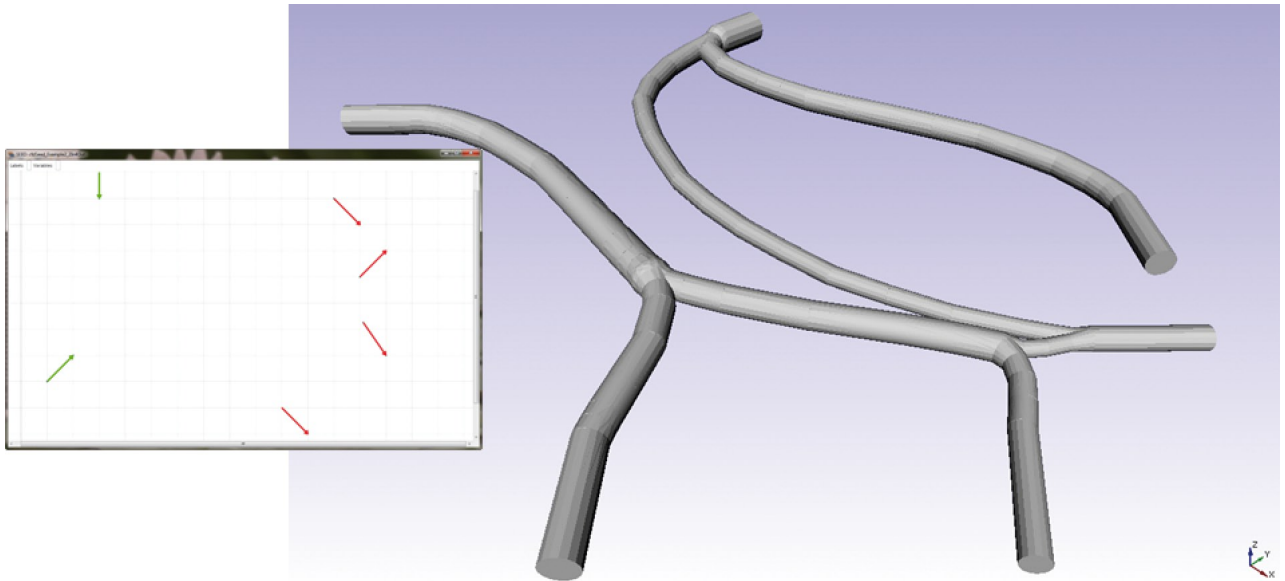

1 | The automated synthesis of fluid channels is created for a complex test problem consisting of 2 inputs and 4 outputs. The result shows a solution with smooth curvature and smooth changes in diameter to minimize loss. In the second problem, a cantilever truss is created by applying rules that include heuristics to minimize beam bending. This approach to shape synthesis is unlike many current approaches which take hours to complete. Campbell's results can include meaningful manufacturing constraints and several near-optimal solutions are created quickly.

Focus Group Aircraft Stability and Control

Dr. Matthias Heller | Rudolf Diesel Industry Fellow

Markus Geiser | Doctoral Candidate

© Prof. Florian Holzapfel, Flight System Dynamics, TUM

50 Highlights and Achievements



Matthias Heller

Research and reality – bridging the gap between theory and real flight

There is no automotive application where a “black-out failure” of the control system inevitably causes dramatic consequences, with exception to aviation (“flying heavier than air”). The criticality of any degradation is so tremendous that a fail-operative/fail-safe characteristic of this vital system is indispensable. Nevertheless, superb capabilities of human pilots have been highlighted with regard to certain spectacular incidents, e.g. an Israeli pilot flying an F-15 with only one wing remaining or a DHL Airbus landing safely despite all primary controls having failed. This demonstrates impressively how a degraded aircraft may still be kept aloft. However, how should this be accomplished if no pilot is present at all, i.e. in an unmanned aircraft? Furthermore, could the pilot of a manned aircraft be supported by active (potentially adaptive) control if things go wrong? Promising new results from control theory research suggest appropriate solutions. Nonetheless, due to the specific requirements and boundary conditions of the aerospace environment, in particular the totally unresolved certification problem (“certification collapse”), these new methods are far away from application within production aircraft.

Hence, it is the main objective and vision of the TUM-IAS Focus Group Aircraft Stability and Control to bridge this gap by maturing the modern adaptive control techniques and to address their certification capability in order to empower their beneficial application within the Flight Control System (FCS) of real operational aircraft in order to keep the system airborne as long as it is physically feasible. In order to provide evidence of the novel methods and approaches and particularly to demonstrate their applicability in flight, the Focus Group (co-)operates several flying research testbeds (figure 1). Additionally, within the dedicated lead project SAGITTA, a multidisciplinary, advanced research demonstrator, an unstable Low Observability Flying Wing UAV (figure 1), is developed as embodiment of our vision, yielding a close and fruitful collaboration between CASSIDIAN and TUM, involving a broad range of outstanding partners. Within the general project work-share, the Focus Group Aircraft Stability and Control holds the responsibility for the overall FCS system design, i.e. the safety critical core discipline, the consequences of which in case of failure have to be rated as catastrophic (figure 2). This comprises the definition of development methods and processes like model based system design or safety assessment as well as coping with certification aspects and requirements.

In 2012, with sight set on the maiden flight of the SAGITTA Demonstrator in 2015, the basic flight control system design and associated development steps have been accomplished as the fundamental prerequisite for the subsequent demonstrator construction. Alongside the decisive functional control surface layout and assessment where a radically novel “vortex split flap” yawing moment generator has been elaborated (figure 3), the final “triplex” multidisciplinary (hardware) system design together with the associated safety assessment was accomplished.

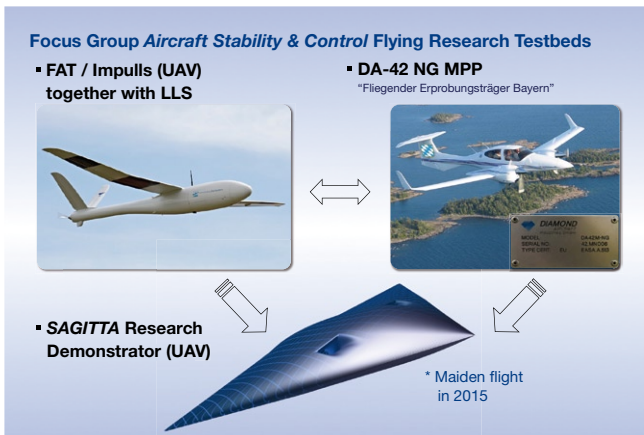

1 | Flying Testbeds operated by the Focus Group ©FSD

Parallel to the current system design dominating the SAGITTA Demonstrator development, two doctoral candidates also performed noteworthy research in the area of applied adaptive control, culminating in the first flight of an adaptive controller on the FAT/IMPULLS on the 16th of November 2012 (see figure 4). Furthermore, an ATOL (automatic take-off and landing) feasibility study for SAGITTA was initiated and started in summer 2012, leading to promising results concerning model based requirement derivation and best approach trajectory planning.

The SAGITTA project was presented to a wide audience and attracted a lot of attention at the Deutsche Luft- und Raumfahrtkongress in Berlin, featuring an

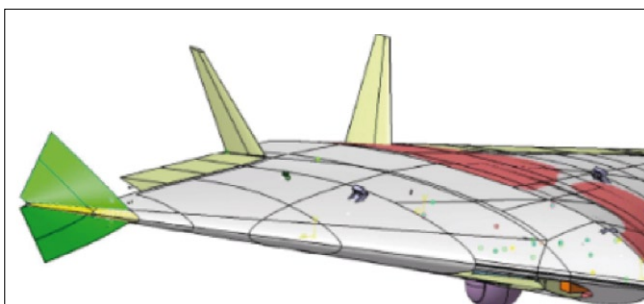

3 | Unconventional "Vortex Split Flap" Control Surface Design ©TUM

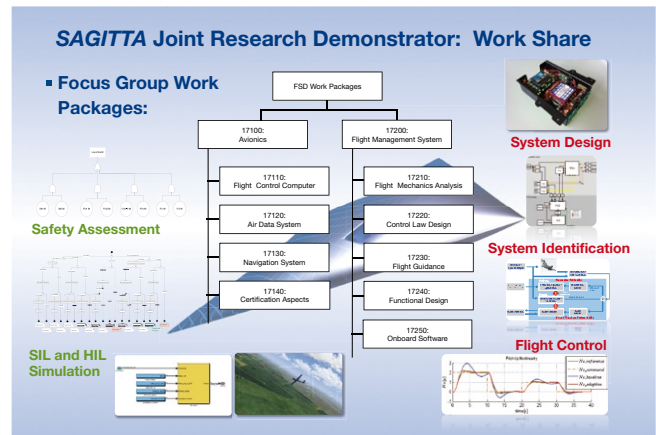

2 | SAGITTA Demonstrator Focus Group Responsibilities ©FSD

own dedicated session, as well as at the AIRTEC UAV World in Frankfurt/Main. In 2013, the research group will extend and deepen the respective investigations, focusing on the control algorithms in order to move the development and build-up of the SAGITTA Demonstrator forward, thus realizing our vision to make the first adaptive controlled UAV fly autonomously in the German sky, (and come back landing automatically and safely).

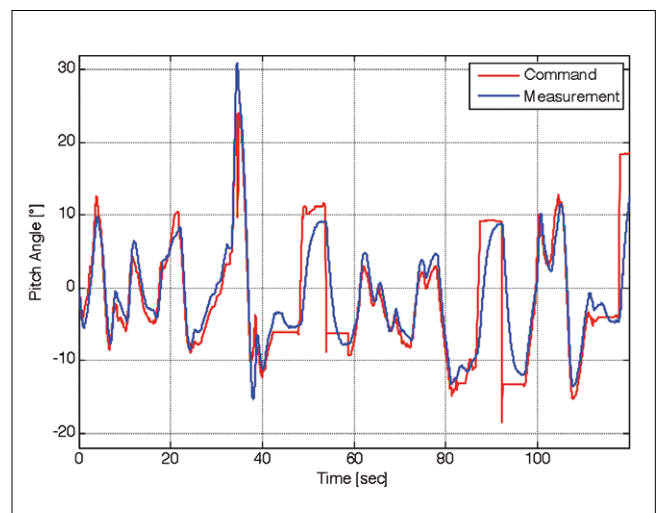

4 | Improved Pitch Angle Tracking by Adaptive Control ©FSD

Selected Publications

[1] M. Geiser and M. Heller, "Flight Dynamics Analysis and Basic Stabilization Study in Early Design Stages of the SAGITTA Demonstrator UAV," in *DGLR Deutscher Luft- und Raumfahrtkongress*, Berlin, 2012, DLRK2012_281329.

[2] M. Heller, F. Schuck, L. Peter, and F. Holzapfel, "Hybrides Flugsteuerungssystem für zukünftige Kleinflugzeuge," in *DGLR Deutscher Luft- und Raumfahrtkongress*, Berlin, 2012, DLRK2012_281349.

Focus Group **Cognitive Technology**

Prof. Alexandra Kirsch | Carl von Linde Junior Fellow

Dr. Kolja Kühnlenz | Carl von Linde Junior Fellow

Dr. Georg von Wichert | Rudolf Diesel Industry Fellow

52 Highlights and Achievements



Alexandra Kirsch



Kolja Kühnlenz

Abstraction and hierarchical concepts in Cognitive Technology

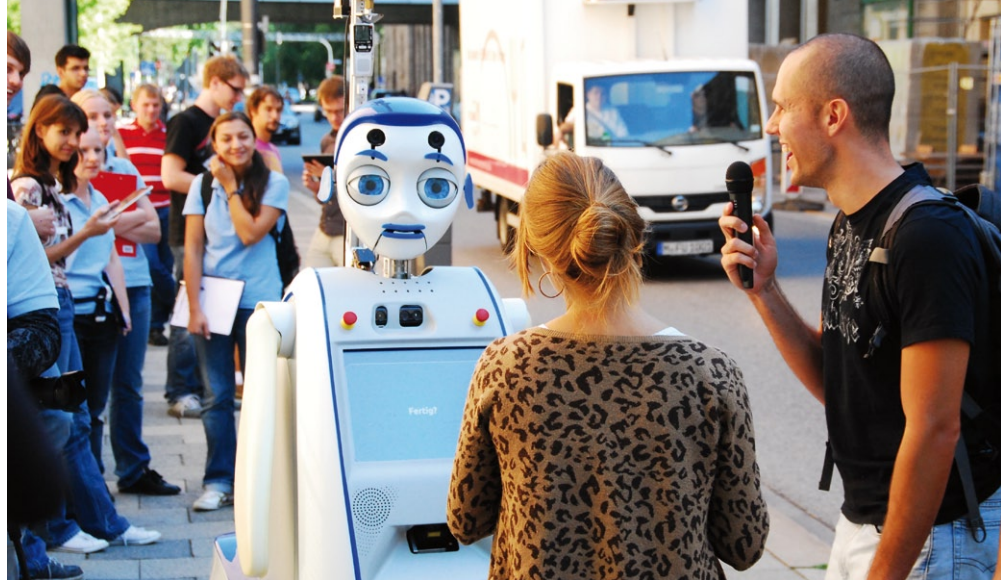

1 | Advanced social skills of the autonomous robot IURO allow intuitive action and interaction in human environments and boost acceptance amongst humans.

Building cognitive technical systems requires techniques for perception, knowledge representation, learning and action selection which are up to the challenges posed by a complex, dynamic and uncertain world. Studies of human cognition have shown that humans use very sophisticated abstract representations to succeed in such environments. Abstraction allows for a concentration of the cognitive processes on essential concepts and thus “compresses” the problem spaces of prediction and planning tasks. It also fosters the generalization of concepts and solutions, which is important to increase a system's behavioral robustness. The use of abstraction as a constitutive feature of cognitive processes would, however, not only help to make technical systems more reliable and efficient, but also ease the interaction with users. Yet general mechanisms for abstraction and how to use such representations to facilitate perception and action are still unknown.

In July 2012 the Focus Group Cognitive Technology held a workshop at the TUM-IAS entitled “The Role of Abstraction and Hierarchical Structures in Cognitive Systems” that brought together researchers from technical fields with cognitive and social scientists to see what we can learn from naturally intelligent systems and how we can build similarly powerful abstraction mechanisms for technical systems in order to make them more flexible, adaptive and understandable for real-world applications.

As humans we rely on context knowledge for interpreting the noisy information we receive via our perceptual system. Context knowledge is what we know about how the world “works”. We acquired this knowledge by experience and teaching; it cannot be directly observed. Here, abstraction and hierarchy play an important role as means to formulate universally applicable rules and facts. This type of knowledge is extremely helpful also for autonomous machines being faced with the full complexity of the real world. As of today, generic methods to use context knowledge in cognitive robots are still in their infancy, especially when we include the lower levels of perception. To this end, we are devising methods to systematically exploit context in autonomous robots. Liu Ziyuan and Dr. Georg von Wichert [5] have shown how this can be achieved given the task of understanding the building structure in indoor mobile robots. The aim here is to develop methodologies that are independent of the particular reasoning task at hand.

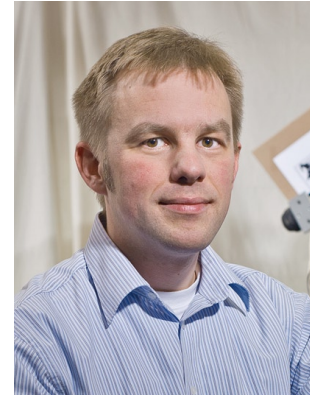

Dirk Wollherr

Abstraction and hierarchical concepts also play an important role for human-robot interaction. Since humans understand the world in abstract concepts, a robot should likewise be able to represent concepts and situations as hierarchical structures. In particular, robots need to understand the current situation and the task a user is trying to achieve in order to act appropriately and offer help when necessary. A challenge for understanding situations is the limitation of robot sensors and the requirement for privacy in human environments. Michael Karg and Prof. Alexandra Kirsch [1] have shown that even simple observations such as the positions of a person and the duration spent at these positions can suffice to make reasonable predictions about the person's current task and next actions. But a hierarchical representation of situations and respective action selection is no guarantee that humans will accept a robot's behavior. Specific evaluation methods and metrics are necessary to assess the acceptance and comfort of users when interacting with a robot [2].



Georg von Wichert

With the vision of robots entering human spaces, acting and interacting with human partners on equal terms, social aspects of robotics becomes an increasingly important factor, especially in human-robot interaction. To this end, Barbara Kühnlenz (née Gonsior) et al. [3] investigated how to efficiently use both human-like and non-human-like feedback modalities in order to optimize proactive information retrieval from task-related Human-Robot Interaction (HRI) in human environments. The approach combines the human-like modalities speech and emotional facial mimicry with non-human-like modalities. Advanced handling of miscommunication further improves intuitive interaction, which is clearly preferred in human evaluation experiments.

Since the interaction of cognitive systems with humans is a central topic in the Focus Group, our organization of the IEEE International Workshop on Advanced Robotics and its Social Impacts (ARSO), held in May 2012 at the TUM-IAS, was a major success. Highlights were two keynote talks of Prof. Klaus Mainzer (Director, Munich Center for Technology in Society, Chair of Philosophy and Philosophy of Science) and Dr. Gisbert Lawitzky (Head, Robotic Technologies, Siemens Corporate Technology). Another highlight was the talk of Bjoern Juretzki (European Commission) on a representative study on public attitudes towards robots in all EU member states. Among the participants were delegates from top-level international universities and research institutions as well as from industry (Honda, Evolution Robotics, Siemens, Hitachi, Aldebaran, etc.) and governmental bodies, and from philosophy, psychology and social sciences to engineering and computer science resulting in a stimulating discourse. A follow-up activity currently conducted is the publication of extended versions of a subset of ARSO papers with an additional open call in a special issue of the International Journal of Humanoid Robotics to be issued in late 2013.

Selected Publications

- [1] M. Karg and A. Kirsch, "Acquisition and Use of Transferable, Spatio-Temporal Plan Representations for Human-Robot Interaction," *IEEE/RSJ International Conference on Intelligent Robots and Systems (IROS)*, Vilamoura, 2012, pp. 5220–5226.
- [2] C. Lichtenthaler, T. Lorenz, and A. Kirsch, "Influence of Legibility on Perceived Safety in a Virtual Human-Robot Path Crossing Task," *21st IEEE International Symposium on Robot and Human Interactive Communication (Ro-Man 2012)*, Paris, 2012, pp. 676–681.
- [3] B. Gonsior, C. Landsiedel, N. Mirnig, S. Sosnowski, E. Strasser, J. Zlotowski, M. Buss, K. Kuhnlenz, M. Tscheligi, A. Weiss, D. Wollherr, "Impacts of Multimodal Feedback on Efficiency of Proactive Information Retrieval from Task-Related HRI," *Journal of Advanced Computational Intelligence and Intelligent Informatics, Special Issue on Cognitive Infocommunications*, vol. 16, no. 2, pp. 313–326, 2012.
- [4] F. Rohrmuller, D. Wollherr, M. Buss, "MuRoCo: A Framework for Capability- and Situation-Aware Coalition Formation in Cooperative Multi-Robot Systems," *Journal of Intelligent & Robotic Systems*, vol. 67, pp. 339–370, 2012.
- [5] L. Ziyuan and G. von Wichert, "Extracting Semantic Indoor Maps from Occupancy Grids," *Robotics and Autonomous Systems*, Elsevier, 2013. doi:10.1016/j.robot.2012.10.004

Focus Group **Networked Dynamical Systems**

Dr. Dragan Obradovic | Rudolf Diesel Industry Fellow

Herbert Mangesius | Doctoral Candidate

© Prof. Sandra Hirche, Information-Oriented Control, TUM

Highlights and Achievements



Dragan Obradovic

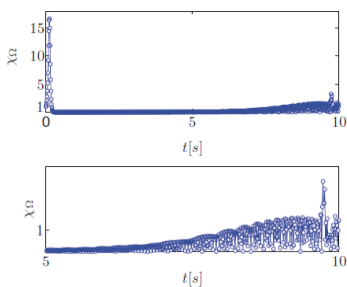

1 | Global phase frustration (sum of squared phase velocities) over time: oscillations and first peak developing from synchronized solution.

Activities in the area of networked dynamic systems

55

Clock Synchronization Distributed synchronization of clocks in a network has lately been a very important topic in the networked systems control literature because of the results showing that local information exchange between individual clocks (i.e. oscillators) can lead to a global convergence to a common time. These algorithms are typically referred to as consensus-type algorithms. The convergence rate of a consensus algorithm is, among others, related to the properties of the graph describing the topology of the communication links between individual clocks. On the other hand, clock synchronization algorithms following the IEEE 1588 standard for the master-slave clock synchronization is state of the art in real-time industrial automation systems.

At the workshop organized by the Lund University in October 2012 [1], both approaches to clock synchronization were presented and compared. There is a strong belief that this event will shape the research directions within the consensus algorithm community.

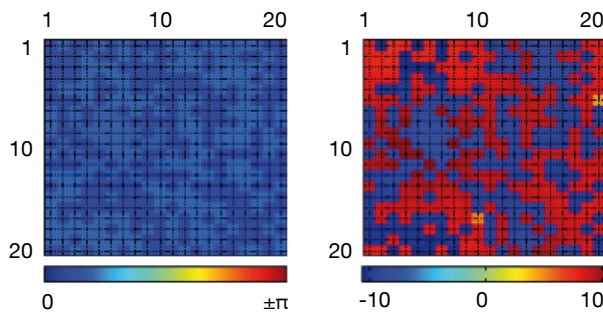

2 | Phase angles (left), and local coupling tension (right) in [rad/s], corresponding to the peak in Fig. 1 at t=9.8 sec.

Dynamics of the Power Grid The analysis of the stability and non-equilibrium behavior in electric power grids is the focus of the PhD work of Herbert Mangesius. The dynamical interaction of electrical and mechanical components has been captured in a Kuramoto-type approximation of the system dynamics [2].

The work on this topic has continued in two main directions. Firstly, by extending the classic Kuramoto model, we produced novel dynamic phenomena such as stochastic-like behavior, as seen in figure 1 and figure 2. On that basis we investigate “quenching mechanisms” that lead to spatial-temporal patterns similar to those observed in real power systems. Secondly, possible formalizations of the Willem’s general framework of interconnected systems are investigated in order to perform qualitative and quantitative analysis of complex behaviors in electric grids. The results of those investigations will be reported in publications which are under preparation.

Selected Publications

- [1] D. Obradovic et al., “Precise clock synchronization for industrial automation and other networked applications,” presented at the *LCCC workshop on Information and Control in Networks*, Lund, 2012.
- [2] H. Mangesius, S. Hirche, and D. Obradovic, “Quasi-Stationarity of Electric Power Grid Dynamics Based on a Spatially Embedded Kuramoto Model,” in *American Control Conference*, Montreal, 2012, pp. 2159–2164.

Focus Group Diesel Reloaded

Prof. Gernot Spiegelberg | Rudolf Diesel Industry Fellow

Claudia Buitkamp, Ljubo Mercep, Hauke Stähle | Doctoral Candidates

© Prof. Alois Knoll, Robotics and Embedded Systems, TUM

56 Highlights and Achievements



Gernot Spiegelberg

With full throttle into the learning curve

Diesel Reloaded presents an interdisciplinary and holistic approach to electric mobility. The research is focused on three main areas: system architecture, energy management and human-machine interfaces. All these topics are considered not only inside the vehicle, but also with regards to external communication, traffic and energy network.

In the year 2011 we established the foundations of our research topics, created an ecosystem of partners from academia and industry and successfully constructed and built-up our vehicle prototype, the Innotruck. The emphasis was placed on engineering on the one side and finding long-term cooperation partners on the other. After the successful first project year, we had set quite a high benchmark for the second one. The emphasis was shifted to scientific activities, based around data collection, signal processing and hypothesis testing. With this report we can proudly state that the second project year also yielded excellent results in all major fields. Additionally, we have continuously demonstrated the societal relevance of our research and communicated it to broader public via numerous media appearances.



1 | The project team directly after the successful Drive-By-Wire test in June 2012

The research in the area of next-generation system architecture has been further discussed with the fortiss research institute of the Technische Universität München, resulting in a joint publication on the future ICT architectures for electric vehicles [1].



2 | The Innotruck as a micro smart grid at the Hannover Messe 2012

Research in the area of human-machine interface has gone in several directions. The main ones involve modeling the information flows in the HMI, data mining in order to determine the driver's fitness, probability framework for describing user and system state and fusing the HMI with the driver assistance systems [2]. In order to manage the large number of energy sources and sinks in our vehicle, a market-based supply-and-demand model has been developed. This model is transferrable to an array of similar hybrid-electric utility vehicles, with their own specific needs and usages. First steps to implementing the strategy on Siemens ENUBA vehicles, part of the eHighway project, have already been made in the last months of 2012. The drive-by-wire system in the Innotruck has been successfully tested in June and talks have started with SGS-TÜV in order to obtain the road permission.

The vehicle has become a meeting point for an array of science and energy partners coming from energy, transport and communication sector. It is simultaneously an origin of new e-mobility concepts and prototypes. A total of 35 industrial and academic partners are currently participating in the project. A signal processing method essential for the work of the driver assistance module has been patented at Technische Universität München together with Siemens in May. Through our cooperation with OSRAM, we have outfitted the Innotruck with a new LED-based interior

lighting system. The vehicle can now adapt the ambient lighting to personal profiles and mental states.

After our project was presented in 13 independent news articles and TV/Video pieces in the first year, the second year more than doubled this result with 28 articles and pieces, including a short documentary by Discovery Channel. The Innotruck has been nominated for the eCarTec Award 2012 in the category "Project Concept / Vision". Our plans for the year 2013 include finalizing the three research topics through a large number of summarizing publications and closing all the open work on the demonstrator. The hybrid drive in the Innotruck will be tested with the new energy management and the results compared with the ones of the Siemens ENUBA vehicle.

Selected Publications

- [1] C. Buckl, A. Camek, G. Kainz, C. Simon, L. Mercep, H. Staehle, and A. Knoll, "The software car: Building ICT architectures for future electric vehicles," in *2012 IEEE International Electric Vehicle Conference (IEVC)*, Mar. 2012, pp. 1–8.
- [2] J. Stoeck, L. Mercep, G. Spiegelberg, and A. Knoll. "Platform-independent interface for the management of sensor-generated power and data flows in an automotive data-centric architecture," in *6. VDI/VDE Fachtagung USEWARE 2012 - Mensch-Maschine-Interaktion*, Deutsches Forschungszentrum für Künstliche Intelligenz DFKI, Kaiserslautern, Dec. 2012, pp. 33–36.

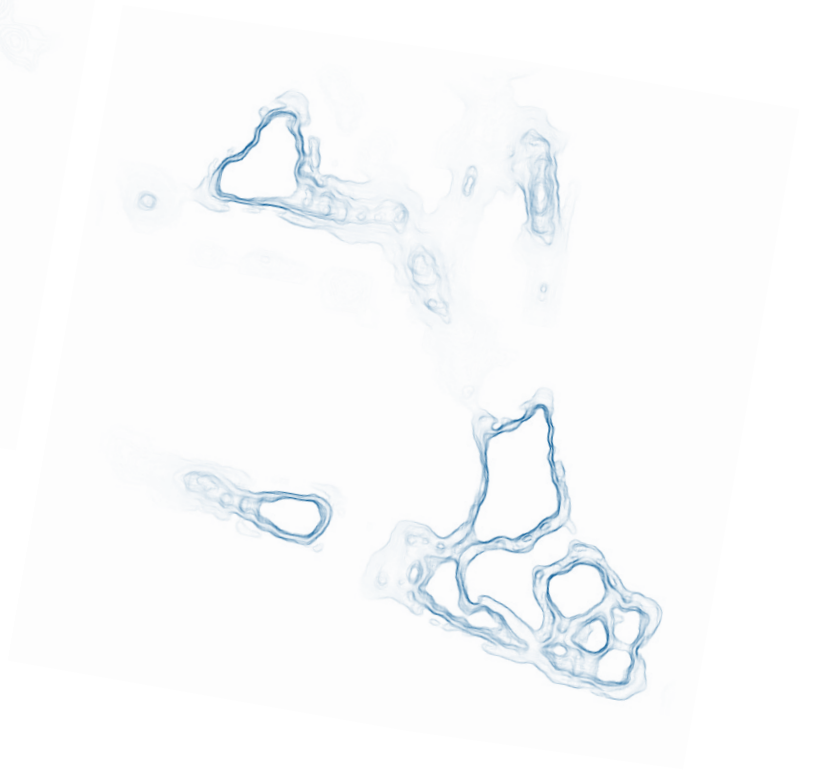
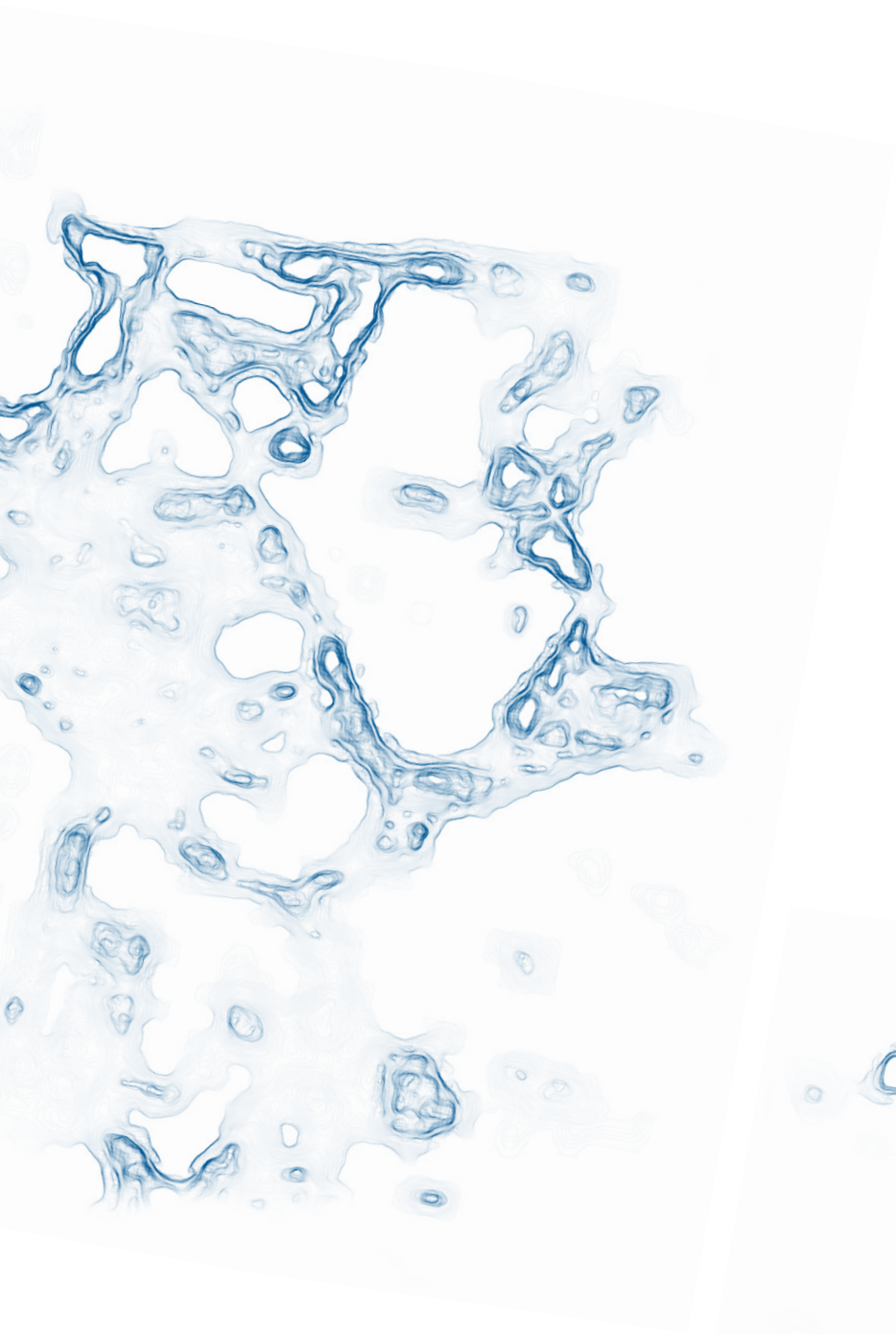

Advanced Cardiac Mechanics Emulator

Advanced Computation

High-Performance Computing

Advanced Stability Analysis

Computational Biomechanics

Focus Group **Advanced Cardiac Mechanics Emulator**

Prof. Michael Ortiz | Hans Fischer Senior Fellow

Andreas Nagler | Doctoral Candidate

Dr. Cristóbal Bertoglio | Postdoctoral Researcher

© Prof. Wolfgang A. Wall, Computational Mechanics, TUM

60 Highlights and Achievements

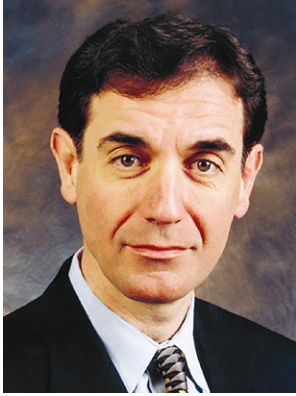

Michael Ortiz

The advanced cardiac mechanics emulator (ACME)

The Advanced Cardiac Mechanics Emulator (ACME) is a collaborative effort between TUM, UCLA and Caltech, whose chief objective is the development of a complete computational model of the human heart enabling detailed and high-fidelity predictions of cardiac function in both healthy and diseased individuals. ACME combines the most advanced biomechanical models to date of myocardial tissue, hemodynamics and the electrophysiological response of the heart with the latest advances in high-performance and extreme computing.

The first challenge in carrying out this program is to model the geometry of the human heart. To date, most heart geometrical modeling has focused solely on ventricular geometry extracted from ex vivo data and, consequently, there is a paucity of solid models that account for all four chambers on the basis of *in vivo* data. We have addressed this gap by using *in vivo* ECG-gated computer tomography (CT) in order to construct a finite element (FE) discretization. In addition, in order to simulate the physiology of the heart, a model of the myocardium histology, specifically the intricate distribution and orientation of muscle fibers whose coordinated contraction results in the systole of the heart, needs to be overlaid on top of the solid model. Most fiber models to date employ parameterized representations, or rule-based models (RBM). These models are often oversimplified and offer limited fidelity as regards the representation of the actual fiber histology. This poor fidelity in turn results in non-physiological artifacts and non-predictive simulations. Alternatively, Diffusion Tensor Magnetic Resonance Imaging (DT-MRI) constitutes a non-invasive technique that has been shown to result in accurate representations of the fiber organization of the heart.

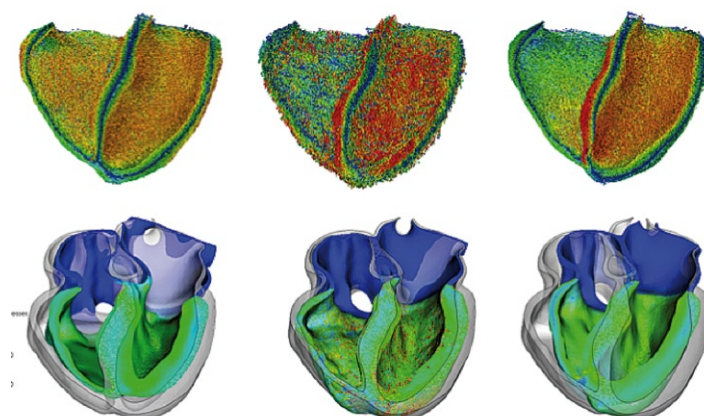

1 | Top: Short-axis view of the ventricular fiber organization, colored by the magnitude of long-axis component. Bottom: Snapshots of the contraction simulation at time 0.3 s, superposed with the original geometry (grey). Left: RBM with constant fiber distribution (mostly used in the literature). Center: fibers from DT-MRI. Right: optimized RBM fibers from DT-MRI.

However, the geometry derived automatically from the MRI data is often noisy and needs to be modified in order to eliminate artifacts and ensure physiologically meaningful geometries. DT-MRI data is particularly sparse and uncertain towards the periphery of the myocardium, requiring special attention during segmentation, registration, and reconstruction. In order to address these challenges, we have developed a methodology for synergistically combining RBMs and DT-MRI. Specifically we estimate, through the solution of an inverse problem, the degrees of freedom of a RBM, namely the parameters of the angle distribution on the epicardial and endocardial surfaces, from DT-MRI data using a static reduced-order Unscented Kalman Filter. Some early results are shown in figure 1. The ultimate aim of this approach is to effectively personalize the myocardial architecture for patient-specific cardiac electromechanical simulations.

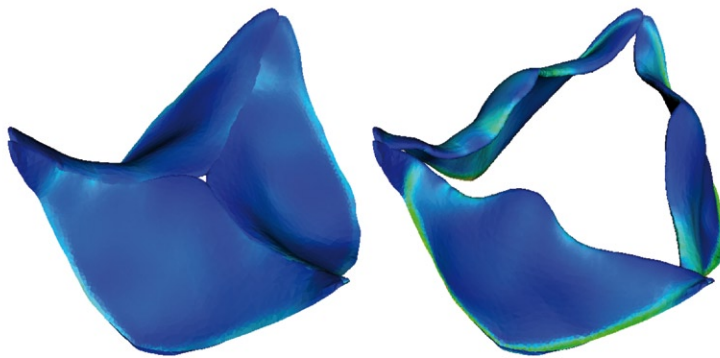

2 | Snapshots of a simulation of the aortic valve: initial (left) and maximal opening configurations (right). Color coding represents levels of effective (Mises) stress.

The geometry and physiology of the human heart valves are particularly complex and require special attention. These valves are: the two atrioventricular (AV) valves, the mitral valve and the tricuspid valve, which connect the atria and the ventricles; and the two semilunar (SL) valves, the aortic valve and the pulmonary valve, which connect to

the arteries that exit the heart. The present ACME myocardium model is modular and includes geometrically precise attachments for the insertion of individual valve models. The modeling of the valves, including the flaps and their fibrous structure, the chordae tendineae and the papillary muscles, is presently in progress and relies on ex vivo data and open-literature analytical models. The current state of development of the valves is illustrated in figure 2, which depicts snapshots from a simulation of the closure of the aortic valve under physiological pressure.

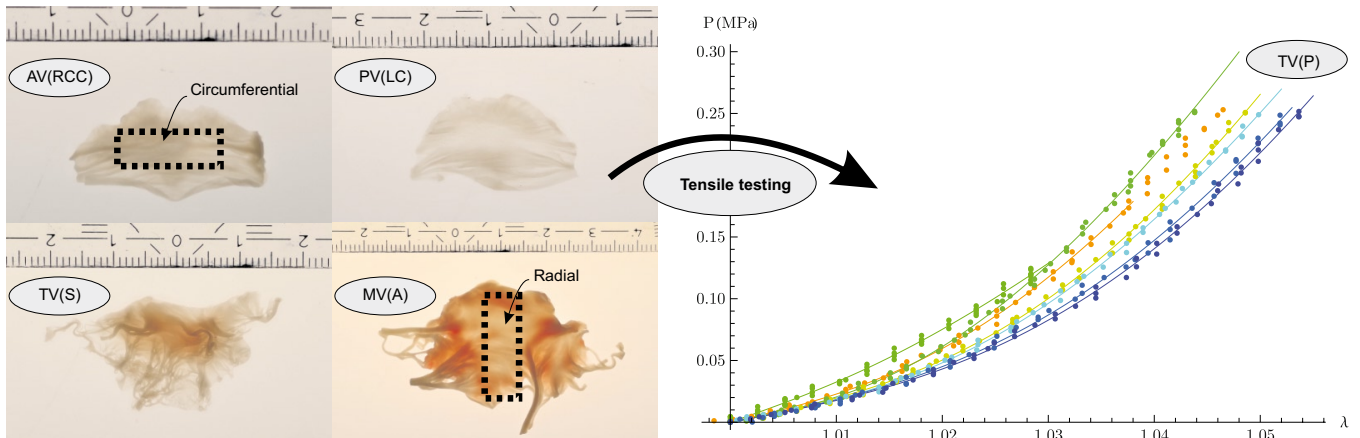

3 | Left: Porcine leaflet samples with cutting directions indicated. Right: Sample stress-strain data measured for the posterior tricuspid valve and Yeoh model fit. Tests and analysis conducted by S. Heyden.

A further obstacle to the predictive modeling of human heart valves is the current paucity of data regarding their mechanical properties. In order to fill this gap, we have conducted uniaxial and biaxial tensile tests on porcine heart valve leaflets. The aim of this work is to characterize the mechanical properties of the entire complement of valves and leaflets under tensile loading. The influence of different experimental testing devices, including clamping materials, as well as the degradation and change in material properties of the examined tissues over several days, have been carefully assessed. The experimental dataset has been characterized by fitting to a two-term incompressible Yeoh model with a view to integration into numerical simulations. Sample specimens and the resulting stress-strain data for the posterior tricuspid valve are shown in figure 3.

The data exhibit a high degree of reproducibility across different specimens and provide a wealth of quantitative information and insight into the structure and mechanical properties of heart valves.

Thus, the data show a trend towards increasingly compliant response in the radial loading direction, as expected on histological grounds given the distribution of fiber orientations in the valves.

Close collaboration with physicians and radiologists from the Klinikum Rechts der Isar ensures the anatomical and physiological correctness of all geometric modeling assumptions. Established connections between the Centers for radiology, nuclear medicine and vascular surgery and the Institute for Computational Mechanics at TUM provide the multidisciplinary framework essential for the success of the ACME project. The ACME project is also expected to benefit from close interactions with the newly founded Munich Heart Alliance and the German Heart Center in Munich. The patient-specific heart models supplied by ACME will contribute to the study and clinical treatment of a number of healthy and diseased conditions of the human heart such as those resulting from myocardial infarction, valvular cardiomyopathy, dilated cardiomyopathy and others.

Overcoming numerical barriers in geometric flow computations



Peter Schröder

Variational principles are at the core of many formulations of physical and geometric laws. Generally speaking, one formulates a potential energy whose minimizers characterize configurations of interest. In Geometry Processing, such energies play a vital role in defining the fairness of a surface and typically involve a measure of the curvature of the surface. Evolution in time towards a potential energy minimum is then realized through a geometric flow, i.e., gradient descent.

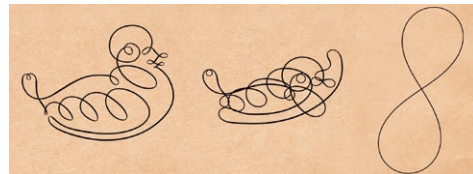

1 | Applying curvature flow to a closed curve is guaranteed to maintain the homotopy class of the curve no matter how complex it is.

Applications range from geometric modeling, such as the design of fair surfaces, to physical modeling, for example in biology where the shape of bi-lipid membrane vesicles is controlled by curvature-based energy. Computationally, such an evolution in time is subject to hard numerical barriers

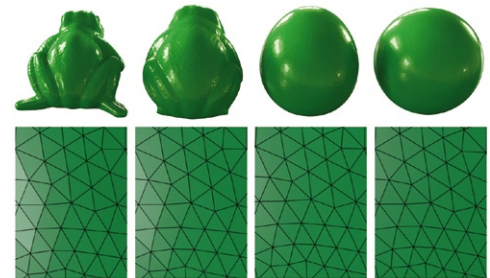

2 | A geometric model flows to the round sphere in three time steps while maintaining mesh quality throughout the flow.

forcing impractically small time steps to ensure stability. We have recently been able to reformulate such energies directly in terms of curvature variables. This essentially removes time step restrictions at the cost of specifying the integrability conditions necessary to ensure that a given curvature function heralds from an actual surface. Surprisingly, this is possible using linear algebra only. The resulting algorithms are orders of magnitude faster than any previously known approaches and have a broad set of applications.

Selected Publication

[1] K. Crane, U. Pinkall, and P. Schröder, "Robust Fairing via Conformal Curvature Flow," submitted for publication.

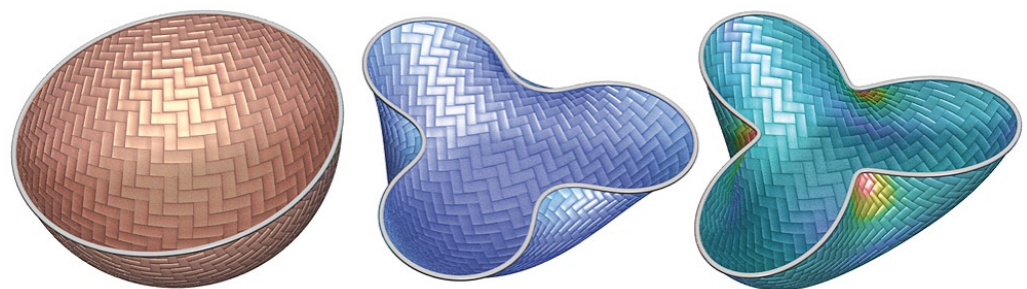

3 | The underlying mathematics enables a rich set of practically relevant boundary conditions.

Focus Group High-Performance Computing (HPC)

Prof. Markus Hegland | Hans Fischer Senior Fellow

Dr. Miriam Mehl | Carl von Linde Junior Fellow

Christoph Kowitz, Valeriy Khakhutskyy, Benjamin Uekermann | Doctoral Candidates

64 Highlights and Achievements

Supercomputing on trees, curves, and fractals



The year 2012 has been a very success- and eventful time for the HPC Focus Group at TUM-IAS. We had a lot of guests, hosted two conferences, welcomed a new Fellow, and lost a Postdoctoral Candidate to Stuttgart. Let's try to bring things in an order:

In March, Prof. George Biros (The University of Texas at Austin, Gordon-Bell Prize 2010) joined us as a Visiting Fellow. We had very fruitful

discussions with him on the usage of self-similar space-filling curves (continuous and surjective mappings between the unit interval and a two- or three-dimensional volume) for efficient numerical simulation on the world's largest supercomputers. The key is to exploit the continuity and locality of the space-filling curve to achieve both an optimal domain partitioning and an efficient usage of cache-memory ([1], [2]). In October 2012, Biros was awarded a Hans-Fischer Junior Fellowship. We are looking forward to a great cooperation on the multi-core track of our group with a particular focus on octree based algorithms and their (energy-)efficient implementation. Currently, we are preparing the implementation of a joint particle simulation.

1 | Barnsley fern, named after Prof. Michael Barnsley

After Christoph Kowitz had spent the winter in Australia, where he and Prof. Markus Hegland developed a new stable sparse grid method to simulate plasma-physics with a minimal number of data points but still high accuracy [3], summer 2012 marked the next phase of our cooperation with the group at the Australian National University (ANU). Prof. Hegland (joined partly by his Doctoral Candidates Brendan Harding and Matthias Wong) stayed in Munich for intensive research and a lot of exchange with our guests: Dr. Peter Strazdins (ANU) delivered important input on the performance analysis of large scale applications on supercomputers and clouds. Prof. Michael Barnsley (ANU), renowned as author of the book *Fractals Everywhere*, came to the TUM-IAS for a week in August. We examined the potential of fractal theory that can describe both space-filling curves and sparse grid, two main ingredients of our algorithms. From ETH Zurich, we welcomed Prof. Martin Gutknecht, who gave a talk on deflated BiCG and related solvers, efficient solvers for a special challenging type of equation. Prof. Henryk Wozniakowski (Columbia University, University of Warsaw) introduced us to the field of Information-Based Complexity (IBC), an important topic for multi-dimensional problems as it aims at answering the question whether it is possible to overcome the curse of dimensionality, i.e., the fast increase of data points with growing dimensionality. Here, the answer seems to be 'no' in general, but 'maybe' for special cases.



Miriam Mehl



Markus Hegland

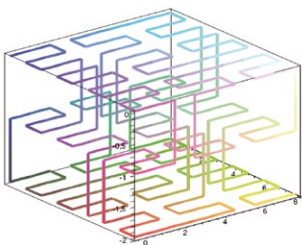

2 | Iterate of the space filling Peano curve used in our simulation codes

Research Member: Prof. Dirk Pflüger

© Prof. Hans-Joachim Bungartz, Scientific Computing, TUM

In June, we had the ISPDC (International Symposium on Parallel and Distributed Computing) at the LRZ. With financial support of the TUM-IAS, we could bring together very attractive invited speakers: Prof. Hester Bijl (TU Delft), Prof. Arndt Bode (TUM, LRZ), Prof. Thomas Ertl (University of Stuttgart), Prof. Markus Hegland, Dr. David Ketcheson (KAUST, Saudi-Arabia), Dr. Lois Curfman McInnes (Argonne National Laboratory), Prof. Wolfgang Nagel (TU Dresden), Prof. Achim Streit (KIT), and Dr. Rio Yokota (KAUST). Two weeks later, the 2nd Workshop on Sparse Grids and Applications was hosted at TUM-IAS with an international group of participants (Germany, Japan, Vietnam, Switzerland, Netherlands, Australia, USA, and Great Britain) and innovative talks given by members of our Focus Group.

Finally, 2012 was also successful in terms of ensuring the continuation of our work: We have been granted two projects in the DFG priority program 1648 *SPPExa – Software for Exascale Computing*. The first project (*EXAHD – An Exa-Scalable Two-Level Sparse Grid Approach for Higher-Dimensional Problems in Plasma Physics and Beyond*, speaker: Dr. Dirk Pflüger) continues and enhances our work on multi-dimensional problems, whereas the second project (*ExaFSA – Exascale Simulation of Fluid-Structure-Acoustic Interactions*, speaker: Dr. Mehl) focuses on a challenging multi-physics application with a great potential to develop methods that are applicable for a wider range of multi-physics scenarios.

In addition, the work at TUM-IAS is nicely complemented by our host chair's research around the new Intel MIC architecture and SuperMUC. Just to mention two highlights: Alexander Heinecke was involved in building the first merely MIC-based cluster (rank 1 in the current Green 500 list); a team around Wolfgang Eckhardt, Alexander Heinecke, and LRZ staff has just managed to do a world record run on SuperMUC - a molecular dynamics simulation with $4.15 \cdot 10^{12}$ molecules on more than 140,000 cores. These activities prepare the ground for the Focus Group's multi-core track in a perfect way.

A last remark concerns an enjoyable incidence that, however, shrank our group by one: Dr. Pflüger got an appointment as a Junior Professor (tenure track) in the SimTech cluster of excellence at the University of Stuttgart in May 2012.

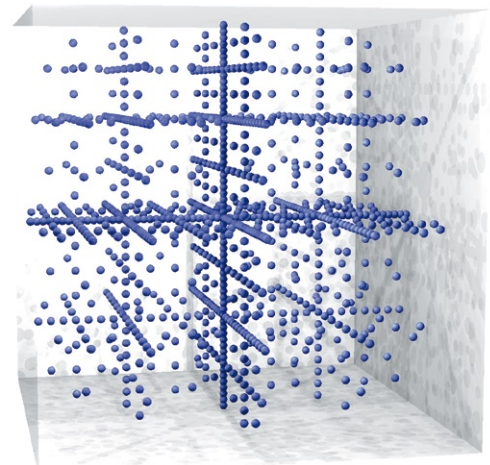

3 | Three-dimensional sparse grid

Selected Publications

- [1] P. Neumann, H.-J. Bungartz, M. Mehl, T. Neckel, and T. Weinzierl, "Coupled Approaches for Fluid Dynamics Problems Using the PDE Framework Peano," *Commun. Comput. Phys.*, vol. 12, no. 1, pp. 65–84, 2012.
- [2] I. Lashuk, A. Chandramowlishwaran, H. Langston, R. Samath, A. Shringapure, R. Vuduc, Y. Ying, D. Zorin, and G. Biros, "A massively parallel fast multipole method on heterogeneous architectures," *Commun. ACM*, vol. 55, no. 5, pp. 1–9, 2012.
- [3] C. Kowitz, D. Pflüger, F. Jenko, and M. Hegland, "The Combination Technique for the Initial Value Problem in Linear Gyrokinetics," in *Lecture Notes in Computational Science and Engineering (LNCSE)*, vol. 88, *Sparse Grids and Applications*, M. Griebel and J. Garcke Eds. London: Springer, 2012, pp. 205–222.

Focus Group **Advanced Stability Analysis**

Prof. Raman I. Sujith | Hans Fischer Senior Fellow
Ralf Blumenthal, Sebastian Bomberg | Doctoral Candidates
© Prof. Wolfgang Polifke, Thermodynamics, TUM

66 Highlights and Achievements



Raman I. Sujith

In line with our ultimate goal of predicting and controlling instability in industrial combustors, last year we focused mainly on (1) establishing a rigorous framework to couple flow, sound and combustion using the method of multiple scales, and (2) establishing tools for non-modal stability analysis. Prof. Wolfgang Polifke and doctoral candidates Ralf Blumenthal and Sebastian Bomberg visited IIT Madras in the first quarter of 2012, where we formulated a more complete mathematical framework to describe flow-combustion-acoustic interaction. We also worked on tools for non-modal stability analysis and on understanding the dynamics of premixed flame. In particular, a time-domain representation of flame front kinematics in terms of response functions was derived in a rigorous manner. This allows identifying clearly the relevant time scales, and gives evidence that response functions provide a complete representation of flame dynamics.

In the summer, Prof. Raman I. Sujith along with his doctoral candidates Priya Subramanian and Lipika Kabiraj visited Munich. We were joined by Prof. Arun Tangirala (IIT Madras) with whom we collaborated on system identification as applied to flame dynamics. We also organized a workshop on system identification. The entire group worked in close collaboration on identifying the dynamics of premixed flames. We worked on examining the role of internal flame dynamics and an appropriate norm for measuring the disturbance energy. We adopted the state space approach to formulate our models on combustion-acoustic interaction. Furthermore, we also interacted with other researchers at TUM-IAS including Prof. Markus Hegland, Dr. Miriam Mehl, Dr. Vladimir García Morales and Prof. Sanjoy Mitter.

During the rest of the year we continued to work on these issues. We coupled the heat release rate models with the acoustic field in the combustor using the formalism of delay differential equations, and thus developed a novel method to determine stability maps of thermoacoustic systems. In our experimental studies, we observed both the Ruelle-Takens and the quasiperiodic routes to chaos. Moreover, we observed intermittency before the occurrence of flame blowout. The intermittent state was identified as of type II through the recurrence analysis of phase space trajectories reconstructed from the acoustic pressure time trace. These results highlighted the need for a dynamical systems approach towards understanding thermoacoustic instabilities. We are now performing experiments on industrial combustors that have swirling turbulent flow. We are also examining the onset of thermoacoustic instabilities in greater detail. This involves studying the mechanisms underlying the transition from broadband combustion noise to narrowband thermoacoustic oscillations. Additionally, we are trying to propose a statistical theory for modeling and predicting thermoacoustic instabilities.

Selected Publications

- [1] L. Kabiraj and R. I. Sujith, "Nonlinear self-excited thermoacoustic oscillations: intermittency and flame blowout," *J. Fluid Mechanics*, vol. 713, pp. 376–397, 2012.
- [2] J. George and R. I. Sujith, "Disturbance Energy Norms: A Critical Analysis," *J. Sound and Vibration*, vol. 331, pp. 1552–1556, 2012.
- [3] R. S. Blumenthal, P. Subramanian, R. I. Sujith, and W. Polifke, "Novel Perspectives on the Dynamics of Premixed Flames," *Combustion and Flame*, in press.

Focus Group Computational Biomechanics

Prof. Zohar Yosibash | Hans Fischer Senior Fellow

Hagen Wille | Doctoral Candidate

© Prof. Ernst Rank, Computation in Engineering, TUM

Highlights and Achievements

Activities during third year of Fellowship

67



Zohar Yosibash

Three exciting fellowship years came to an end in the summer of 2012, but the scientific thrill and enthusiasm and the fruitful collaboration continues. We are continuing our research towards a patient-specific simulation tool of the human femur to be used in clinical practice: enabling semi-automatic creation and analysis of a femur within less than three hours. After we validated the simulation results on a large cohort of fresh frozen femurs tested *in vitro*, we extended these capabilities for predicting the mechanical response of patient-specific fractured femurs undergoing a total hip replacement using cemented prostheses. This work is further extended to the prediction of the mechanical response of femurs with metastatic tumors having encouraging preliminary results (figure 1) – our methods are demonstrated to well predict the mechanical response (including fracture location) of these pathological bones. Furthermore, we noticed an interesting atypical viscoelastic effect which demonstrates that at the femur level, if it is subject to a constant deflection that induces high stresses, even if the femur does not break immediately, it will after a short time (order of ten seconds). Publications documenting these findings are in preparation.

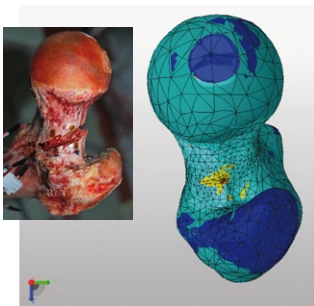

1a | Predicted fracture location by the simulation and actual fracture in test matches closely for a femur with a metastatic tumor.

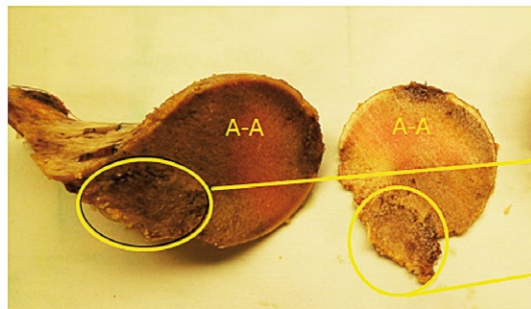

1b | The metastatic lytic tumor and its precise location determined in a histological examination following the test.

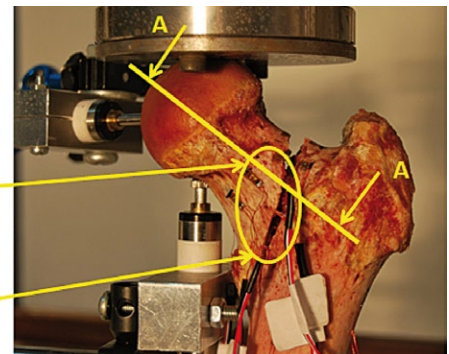

The newly developed finite cell method (FCM) in Prof. Ernst Rank's group, that was demonstrated to perform extremely well for the analysis of bones (in last year's report), is used for the quantification of the influence of bone material uncertainties on bone's response. We extend the FCM to investigate the uncertainty associated with the applied physiological loading on the femur's head. Our doctoral candidate Hagen Wille has spent a couple of months in my lab in Israel during 2012 and will revisit it for a couple of months again in 2013. His research towards quantifying the uncertainties associated with both material properties and loading on the mechanical response of the femur is progressing well and a paper on this topic is in preparation.

Preliminary clinical studies on a “giant cell tumor” in the distal part of a femur was performed on one of our faculty members. Our analysis assisted the orthopedic surgeons to evaluate the risk of fracture and to apply the therapy scenario. We continue to meet orthopedic surgeons to further enhance our clinical trials towards the aim of transition of the simulation capabilities into clinical practice.

The past three years of research resulted in: a) unprecedented patient-specific simulation capabilities of the mechanical response of femurs double blinded validated by experimental observations, b) uncertainty quantification of the simulated results due to material properties spread and loading boundary conditions, c) an enormous increase in simulation speed by the use of the FCM that make the methods applicable for real-time computational steering.

Selected Publications

- [1] Z. Yosibash, “p-FEMs in biomechanics: Bones and Arteries”, *Computer Methods in Applied Mechanics and Engineering*, vol. 249–252, pp. 169–184, 2012.
- [2] Z. Yosibash, A. Katz, and C. Milgrom, “Towards verified and validated FE simulations of a femur with a cemented hip prosthesis”, *Med. Eng. & Phys.*, to be published. doi: 10.1016/j.medengphy.2012.09.007, 2013.

Cells, Molecules and Biomedical Engineering

69

Biomedical Engineering

Biophysics

Biochemistry

Clinical Cell Processing and Purification

Neuroscience



Axel Haase

How to speed up Magnetic Resonance Imaging: reference histogram constrained entropy minimization for undersampled MRI

The increasing need to save measurement time and to temporally resolve fast physiological processes holds a demanding task for modern magnetic resonance imaging (MRI). Due to intrinsically long acquisition times of MRI when compared to physiological processes, such as respiratory, cardiac and patient motion, the resulting motional artifacts pose a major issue in medical MRI. Especially imaging techniques, such as magnetic resonance angiography cardiac imaging and dynamic contrast-enhanced perfusion MRI, aim for very short acquisition times. Sampling rates of 20 frames per second and more are desired.

To overcome the present limitations of conventional MRI acquisition, we developed a reconstruction technique building on the ideas of compressive sampling. By changing the conventional Cartesian data sampling strategy of conventional MRI to a randomized pattern, it is possible to completely change the nature and minimize the energy of errors occurring when reducing the amount of data acquired. We successfully implemented a reconstruction approach (Composite Histogram Constrained Artifact Suppression, called CHiCA), which compensates for artifacts in the image by reversing their effect in its intensity histogram. Image errors, typically associated with incomplete random data acquisition, cause the image's and hence the histogram's entropy to increase. By adapting the corrupted histogram to an estimation of the correct histogram, it is possible to calculate a pixelwise correction mask for image space. The reconstruction itself is implemented in Matlab (The Mathworks, Natick, US) as an iterative regularized optimization problem.

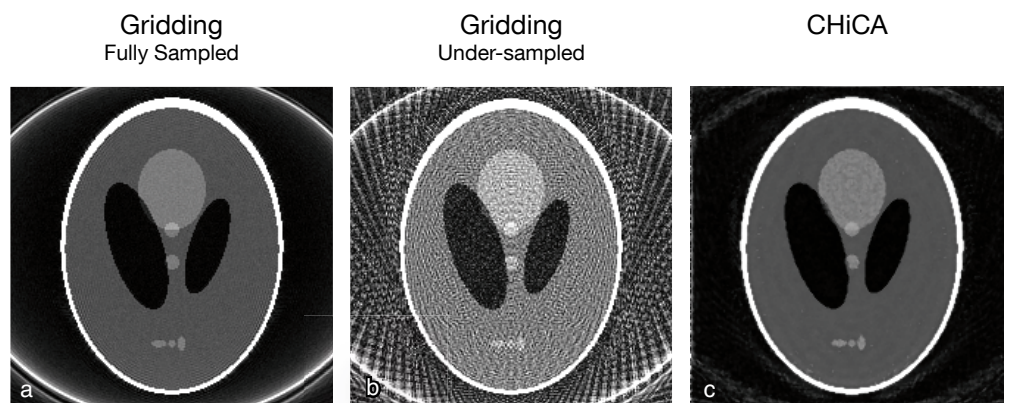

1 | Application of the CHiCA algorithm on a numerical phantom; (a) Original phantom. (b) Reconstruction of a simulated incomplete measurement. (c) Reconstruction of the dataset in (b) using the CHiCA reconstruction.



2 | Results of applying the CHiCA reconstruction on a head MRI; (a) Reconstruction of a full data set. (b) Reconstruction of a measurement only sampling 10% of the required data. (c) Reconstruction of the dataset in (b) using the CHiCA reconstruction.

Figures 1 and 2 present results of the reconstruction algorithm on two different objects. The first specimen is a numerical simulation of the typical contrast and size relations in a human brain MRI. The original phantom, presented in figure 1a, was radially sampled with only a tenth of the necessary data and conventionally reconstructed (figure 1b). Using the CHiCA algorithm (figure 1c), an efficient suppression of most of the artifacts could be achieved. Subsequently, the reconstruction was applied to a radial measurement of a human brain. Figure 2 depicts the fully sampled (figure 2a), the conventional reconstruction of an incomplete data set (figure 2b) and the result after CHiCA application (figure 2c). While artifacts present in the conventional reconstruction were suppressed almost completely, important image feature and details were preserved.

The results prove the possibility to generate artifact free images from only a fraction of the MRI data. Since reduction of acquired data is directly translated in a decrease of measurement time, combining modern sampling strategies and the developed reconstruction approach offers the possibility to accelerate MRI acquisitions by a factor of 10 or more. Consequently, images with much higher spatial resolution can be generated in significantly shorter time. Furthermore, it is possible to acquire dynamic image series with a temporal resolution not achievable with current imaging techniques. Both applications result in images beneficial for future clinical diagnosis.

Selected Publications:

- [1] F. Wiesinger, E. Weidl, M.I. Menzel, M.A. Janich, O. Khegai, S. J. Glaser, A. Haase, M. Schwaiger, R.F. Schulte, "IDEAL spiral CSI for dynamic metabolic MR imaging of hyperpolarized [1-(13) C] pyruvate," *Magn Reson Med*, vol. 68, no. 1, pp. 8–16, 2012.
- [2] T. Gaass, G. Potdevin, P.B. Noël, A. Tapfer, A. Willner, J. Herzen, M. Bech, F. Pfeiffer, A. Haase, "Compressed sensing for phase contrast CT," *AIP Conf. Proc.* 1466, pp. 150–154, 2012.

Focus Group Biophysics

Prof. Hendrik Dietz | Hans Fischer Tenure Track Fellow

Thomas Gerling | Doctoral Candidate

© Prof. Andreas Bausch, Molecular and Cellular Biophysics, TUM

72 Highlights and Achievements



Hendrik Dietz

Molecular engineering with DNA

It is notoriously difficult to observe, let alone control, the position and orientation of molecules due to their small size and the constant thermal fluctuations that they experience in solution. Molecular self-assembly with DNA enables building custom-shaped nanometer-scale objects with molecular weights up to the megadalton regime. It provides an attractive route for placing molecules and constraining their fluctuations in user-defined ways, thereby opening up completely new avenues for scientific and technological exploration. In 2012, we have focused on the following aspects:

How accurate are designed DNA objects?

Together with Dr. Sjors Scheres and Dr. Xiao-chen Bai of the MRC Laboratory of Molecular Biology in Cambridge, UK, we solved the first high-resolution structure of a discrete DNA-based object. The object contained 15728 nucleotides at user-defined positions. The structure confirms structural order in synthetic DNA objects that is comparable to those found in proteins and supports a perspective in which DNA objects serve as high-resolution structural supports for complex tasks such as molecular shape complementarity or even enzyme-like catalysis.

How can we improve the practical assembly?

Design strategies for encoding complex target shapes in DNA sequences have flourished, but the practical assembly of desired objects has often been quite difficult. We found that hundreds of DNA strands can cooperatively fold a long template DNA strand within minutes into complex nanoscale objects at constant temperature [2]. Folding at optimized constant temperatures enabled the rapid production of DNA objects with yields that approached 100%, thereby opening attractive prospects for converting DNA-based self-assembly into a real-world manufacturing technique. In a separate set of experiments we also expanded the range of assembly solution conditions [3].

Applications

Together with Prof. Friedrich Simmel's group at TUM we created DNA-based synthetic lipid membrane channels [4]. We found similarities to the response of natural ion channels, such as conductances on the order of 1 nanosiemens and channel gating, and used the channels as single-molecule detectors. Together with Dr. Ulrich Rant's group at TUM we created DNA gatekeepers for solid-state nanopores [5] that open prospects for stochastic sensing applications.

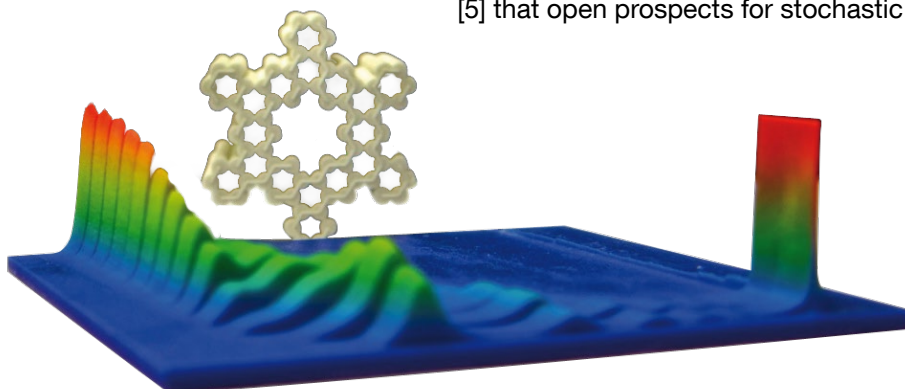

1 | Time-resolved folding of DNA nanostructures as seen in electrophoretic experiments.

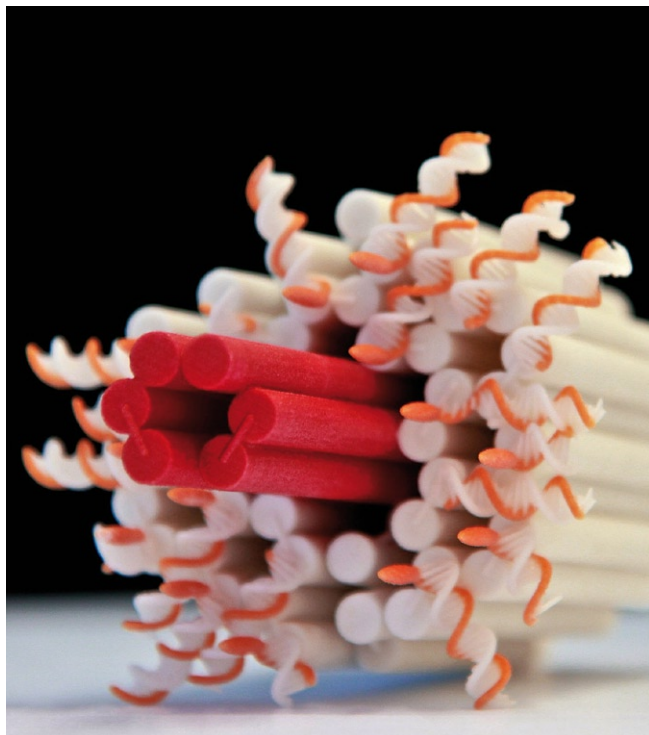

2 | Model of a synthetic lipid membrane channel formed by designed DNA nanostructures.

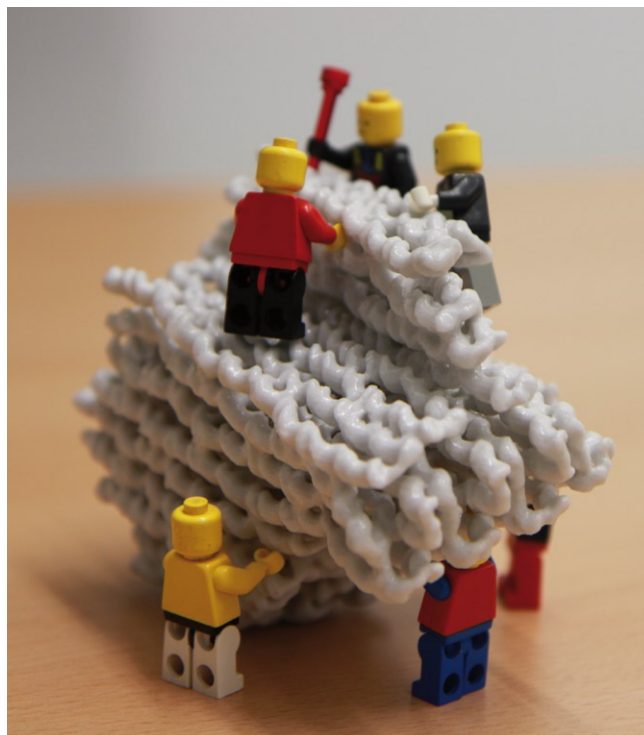

3 | Model of a high-resolution structure of a discrete DNA object, confirming structural order comparable to those found in protein. The results indicate an attractive route for precision nanoengineering with DNA.

Selected Publications

- [1] X. Bai, T. G. Martin, S. H. W. Scheres, and H. Dietz, "Cryo-EM structure of a 3D DNA-origami object," *Proc. Natl. Acad. Sci. USA*, vol. 109, p. 20012, 2012.
- [2] J. P. Sobczak, T. G. Martin, T. Gerling, and H. Dietz, "Rapid folding of DNA into nanoscale shapes at constant temperature," *Science*, vol. 338, pp. 1458–1461, 2012.
- [3] T. G. Martin and H. Dietz, "Magnesium-free self-assembly of multi-layer DNA objects," *Nature Communications*, vol. 3, no. 1103, 2012.
- [4] M. Langecker, V. Arnaut, T. G. Martin, J. List, S. Renner, M. Mayer, H. Dietz, and F. C. Simmel, "Synthetic lipid membrane channels formed by designed DNA nanostructures," *Science*, vol. 338, no. 6109, pp. 932–936, 2012.
- [5] R. Wei, T. G. Martin, U. Rant, and H. Dietz, "DNA origami gatekeepers for solid-state nanopores," *Angew. Chem. Int. Ed.*, vol. 51, no. 20, pp. 4864–4867, 2012.

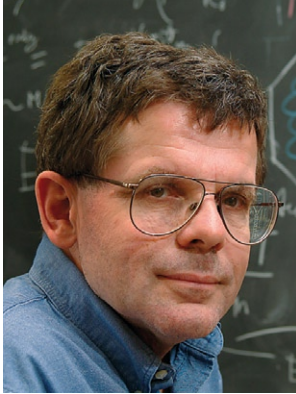

Robijn Bruinsma

Structural engineering of living cells (II)

The biopolymer F-actin is a crucial component of the “cytoskeleton”, the backbone of cells that can grow, shrink, and reform into different morphologies, depending on the need of the cell. In cells, F-actin filaments are arranged into multiple geometries by a variety of cross-linking proteins through a fascinating spontaneous process known as “self-assembly” that is not controlled by the DNA of the cell. In the first stage of the research (“I”), we carried out simulations that established the equilibrium phase diagram of F-Actin filaments and the cross-linking proteins, using a novel simulation platform developed by Christian Cyron and Prof. Wolfgang A. Wall that was both much more realistic in terms of the basic physics of the F-actin filaments, while increasing the effective simulation times to about 1.000 seconds real time. These simulations represented the absolute state of the art in terms of simulations of biopolymer networks.

The functioning of the cytoskeleton under living conditions is not determined, however, by the equilibrium structure, but rather by the response to external forces: Cells can spread out over substrate or even move along a substrate through forces transmitted by the cytoskeleton. The cytoskeleton can behave as a viscous fluid or as a stress-bearing elastic material. If we can understand the physics behind the amazing dynamical performance of the cytoskeleton, then we could learn to design biomimetic materials that reproduces them.

In the second stage of the project we used the computational platform developed at the TUM to probe the dynamical response of the systems whose equilibrium properties were established in I. We focused here on the isotropic bundle network structures that closely resemble the cytoskeleton of living cells, and the synthetic biopolymer networks examined in the Bausch Lab at the TUM. An example is shown in the next figure where simulation results in (I) were compared with F-actin condensation induced by the linker molecule filamin.

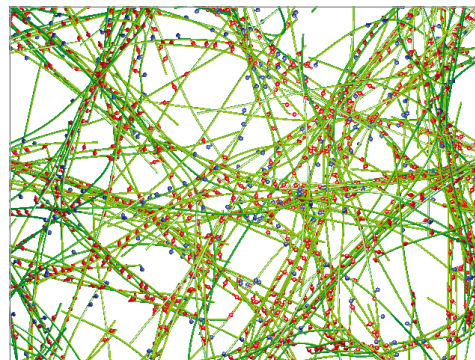

1a | Simulated network of bundles of 3,000 isotropic linkers and 208 filaments.

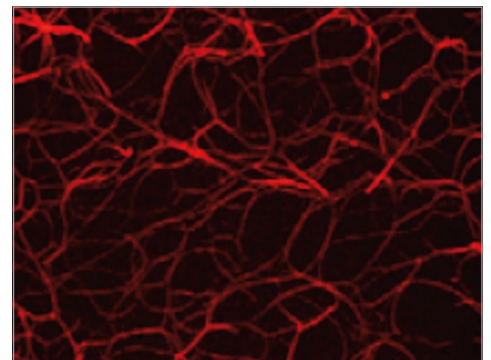

1b | Confocal image of an F-actin/Filamin network of bundles for an F-actin concentration of 2.4 microMolar and a Filamin/Actin molar ratio of 0.1. The scale bar is 100 microns.

Experimentally, the dynamical response of a soft material to a time-dependent applied stress is determined by the methods of rheology. The material is exposed to a low amplitude, periodic shear strain at a certain frequency ω . The resulting shear stress is measured and the ratio of stress and strain produces the complex modulus $G(\omega)$. The whole linear dynamic response of a material to weak perturbations can be “read” from the function $G(\omega)$: how it dissipates elastic energy (determined by the imaginary part G'' of $G(\omega)$: the “loss modulus”) and how the elastic properties of the network (determined by the real part G' , the “storage modulus”) compare with those of free filaments. The complex modulus is the focus also of analytical expressions for the dynamical response as derived from fundamental theory. Numerical simulations measuring $G(\omega)$ so far have been done only on so-called “Gaussian chains”, a very unrealistic model with a number of known defects, such as the inability to transmit torsion, and that only for the case of permanent linkers. It is exactly the ability of the network to remodel itself under the application of external stress that makes this an interesting system for materials science applications.

Since permanently crosslinked networks are better understood, we first studied them. The left panel of the next figure shows the results of a typical rheology experiment on actin networks from the Wirtz group. At low frequency, both storage and loss modulus saturate to a constant value. The storage modulus exceeds the loss modulus significantly, which is the signature of a gel. At high frequency, they

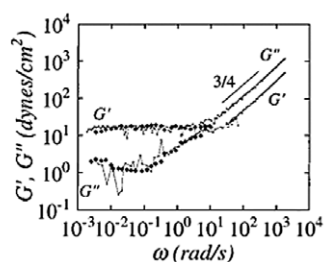

2 | Left panel: linear storage (G') and loss moduli (G'') of actin as measured using mechanical rheometry. Right panel: results of the simulation compared with experiments.

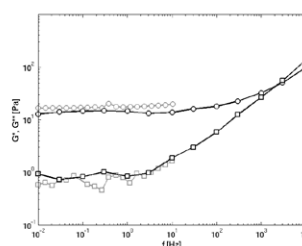

show the characteristic $\omega^{3/4}$ scaling of unlinked semi-flexible polymers. The right hand side shows our simulated results of the complex modulus of a permanent network compared with the corresponding experimental system. The agreement is excellent.

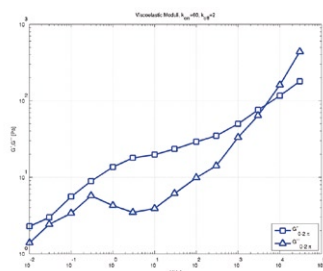

The next step was to include the reversibility of the linker molecules. This dramatically altered the complex modulus. A typical example is shown on the left:

3 | Storage and Loss moduli for a network of reversible linkers with force-independent kinetics.

At low frequencies, both storage and moduli scaled as $\omega^{1/2}$ (black line) and are comparable to each other, in good agreement with recent experiments on reversible networks and a recent theory from the Mackintosh group (Free University). The peak in the loss modulus at the frequency corresponding to the off-rate of the linkers also was expected: It is in agreement with the classical Maxwell theory for viscoelastic materials with a well-defined stress relaxation time τ (the inverse of the “off-rate” of the linkers). For frequencies higher than the off-rate τ^{-1} , the theory predicts a “plateau modulus”: The linkers are effectively frozen so one should recover the permanent linker result. This turned out to be quite wrong: There is no plateau. The storage modulus continues to increase with frequency. The system “knows” at remarkably high frequencies that it is not linked permanently. In collaboration with Alex Levine from UCLA, we showed that this is due to linkers that have a - statistically unusually - short life time but that carry a - statistically unusually - large elastic stress. Similar effects occur in the fracture of materials.

The next step was to include the fact that on and off rates of weak protein bonds are known to be strongly force dependent. From general physical arguments, it was shown by Bell in a classical paper that the off-rate of should have an exponential dependence on the force f applied to the link of the form $\exp fa/k_B T$ with a the characteristic dimension of the weak bond. This introduces strong non-linearity in the rheology. We included the Bell force dependence and repeated the simulations:

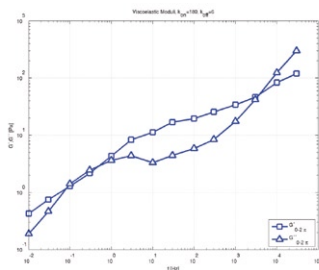

4 | Storage and Loss moduli for a network of reversible linkers with the force-dependent kinetics of the Bell theory.

The high frequency rheology is not affected but at low frequencies the loss modulus is now proportional to frequency. Such a linear dependence is the rheological signature of a liquid. However, the storage modulus retains the theoretically expected $\omega^{1/2}$ dependence. Importantly, because of the difference between the scaling relations, the storage modulus exceeds the loss modulus significantly. That means that the material actually is not a liquid but an exotic gel. We are currently in the process of analyzing these fascinating results and their consequences for biopolymer networks.

In collaboration with Kei Mueller.

Selected Publication

- [1] A. Aggarwal, J. Rudnick, R.F. Bruinsma, and W.S. Klug, “Elasticity theory of macromolecular aggregates”, in *Phys. Rev. Lett.*, vol.109, no. 14, pp. 148102, 2012.

Highlights and Achievements

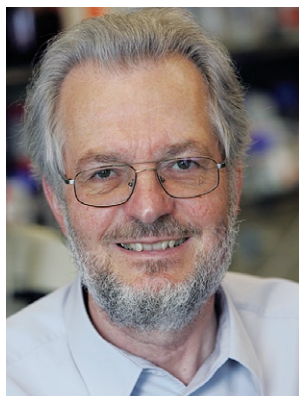

Horst Kessler

In 2012, we published 13 manuscripts with a total impact factor of 84,4. Two highlights are outlined shortly below.

Investigating the different functions of distinct integrin subtypes is essential to understand the interactions between cells and the extracellular matrix. Among the fibronectin binding integrins, the subtypes $\alpha\upsilon\beta3$ and $\alpha5\beta1$ play crucial roles in angiogenesis, embryogenesis and several pathological processes. We were able to functionalize highly selective $\alpha\upsilon\beta3$ or $\alpha5\beta1$ integrin antagonists with a thiol group without loss of activity.

We showed that adhesion of genetically modified fibroblasts, expressing exclusively either the $\alpha\upsilon\beta3$ or $\alpha5\beta1$ integrin subtype, was stimulated selectively on gold nanoparticles coated with the developed peptidomimetics. [1]

Another topic focused on the development of a ligand for the chemokine receptor CXCR4. By incorporation of a peptoid structure motif, in which the side chain of one amino acid is shifted to the neighbored amide nitrogen, an increase of the binding affinity by two orders of magnitude has been achieved. This trick is based on introduction of conformational constraints and led to the most active ligand for this receptor known so far. An important application of this ligand was demonstrated in the inhibition of drug resistant HIV-entry in strains which use this receptor (about 40% of resistant HIV strains). [2]

Selected Publications

- [1] F. Rechenmacher, S. Neubauer, J. Polleux, C. Mas-Moruno, M. De Simone, J. P. Spatz, E. A. Cavalcanti-Adam, R. Fässler, H. Kessler. "Functionalizing $\alpha\upsilon\beta3$ - or $\alpha5\beta1$ -Selective Integrin Antagonists for Surface Coating: A Method to Discriminate Integrin Subtypes In Vitro," *Angew. Chem. Int. Ed.*, vol. 52, pp. 1572–1575, 2013.
- [2] O. Demmer, A. O. Frank, F. Hagn, M. Schottelius, L. Marinelli, S. Cosconati, R. Brack-Werner, S. Kremb, H.-J. Wester, H. Kessler. "A Conformationally Frozen Peptoid Boosts CXCR4 Affinity and Anti-HIV Activity," *Angew Chem. Int. Ed.*, vol. 51, pp. 8114–8117, 2012.

Highlights from the Kessler group

77

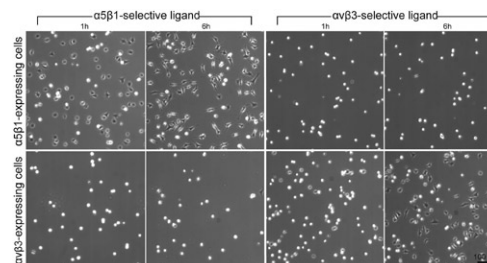

1 | Cell adhesion assay. Low magnification phase-contrast microscope images of $\alpha\upsilon\beta3$ or $\alpha5\beta1$ integrin-expressing fibroblasts seeded onto gold nanoarrays and functionalized with an $\alpha5\beta1$ -selective compound (left) or an $\alpha\upsilon\beta3$ -selective compound (right). The 100 μm scale bar is the same for all images.

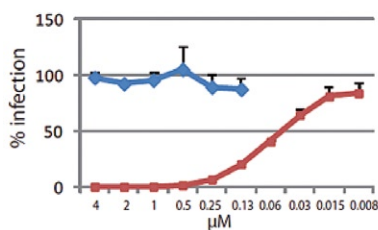

2a | The red curve shows CXCR4 dependent inhibition of HIV-entry, in the blue curve the resistant HIV strain uses the CCR5 receptor for entry, no inhibitory effect of the CXCR4 inhibitor.

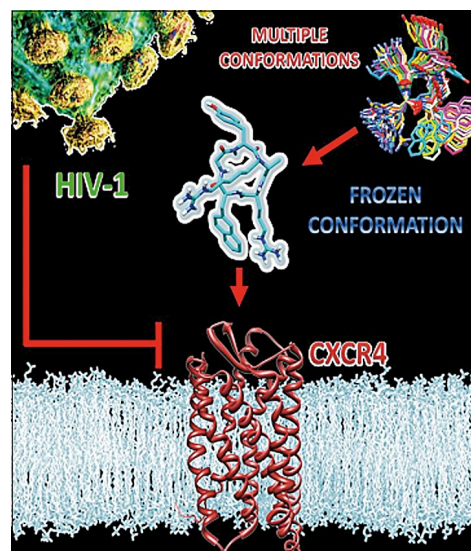

2b | Inhibition of HIV-entry by and rigidified optimized peptoid ligand.

Focus Group Clinical Cell Processing and Purification

Prof. Stanley Riddell | Hans Fischer Senior Fellow
Dr. Christian Stemberger | Carl von Linde Junior Fellow
Jeannette Bet, Paulina Paszkiewicz | Doctoral Candidates

Dr. Stefan Dreher | Postdoctoral Researcher
© Prof. Dirk Busch, Medical Microbiology,
Immunology and Hygiene, TUM

78 Highlights and Achievements



Stanley Riddell



Christian Stemberger

The vision of the Clinical Cell Processing and Purification Focus Group is to set up a fully integrated cell processing platform to facilitate clinical preparation of highly functional and minimally manipulated therapeutic cells for highly individualized medical care. Based on our recent success in developing the tools necessary for optimal cell purification, we focused on transferring our technology to its first clinical application. Our cell processing technology enables us to specifically target and isolate specialized cells of the immune system, which provide unique properties for next generation immunotherapy. Especially in the setting of cancer therapy it is crucial that therapeutic cells are able to completely eradicate the tumor, including single disseminated cells that might give rise to metastases. Furthermore, these highly effective therapeutic cells optimally persist long-term in the patient to instantly prevent reoccurrence of tumor. We identified a special CD8+ T cell subset – so-called central memory T cell – that fulfill both criteria. This cell type can only be characterized by expression of several surface markers for which we successfully developed selection reagents. These reagents allow for the first time not only a highly specific isolation of the cells but in addition can be completely removed afterwards. By performing sequential positive selections for several different markers, we are now able to isolate specific T cell subsets defined by multiple parameters with excellent purity. Our current work involves the establishment of clinical isolation protocols as well as automation of these multiple reversible selection regimens to provide an easy to use and highly standardizable clinical interface.

Based on this new selection technology we also developed protocols to subsequently engineer the obtained pure T cell products by genetic modification with a design tumor-specific receptor. In addition we focused on the introduction of a stably integrated novel “emergency stop” mechanism implemented into the cell product. The addition of a clinically approved reagent leads to elimination of cells that carry an additional safety marker on their surface. First data for feasibility and efficiency of this safety mechanism could be demonstrated in different animal models. To further extend the applicability of designed tumor reactive receptors, we have constructed a programmable tumor specific receptor that allows tuning of the receptor post transfer. The specificity of the engineered cells is interchangeable by choosing a different small molecule from vast libraries of tumor-specific adaptors. The strategy of using versatile cell products that can be directed against multiple tumor targets promises to become a highly innovative concept of individualized and adaptable therapy. Many projects that we have started within the TUM-IAS Focus Group Clinical Cell Processing and Purification have reached a level of maturity where only few data sets are missing for their publication. We are currently applying for new funding sources to perform these experiments. First clinical trials have been initiated, and within the next years we hope to obtain a clearer picture to what extend our new therapeutic approaches will contribute to improved T cell therapy.

Selected Publications

- [1] M. Neuenhahn & D. H. Busch, “Whole-body anatomy of human T cells,” *Immunity*, vol. 38, pp. 10–12, 2013.
- [2] C. Stemberger, S. Dreher, C. Tschulik, C. Piossek, J. Bet, T. N. Yamamoto, M. Schiemann, M. Neuenhahn, K. Martin, M. Schlapschy, A. Skerra, T. Schmidt, M. Edinger, S. R. Riddell, L. Germeroth, D. H. Busch, “Novel serial positive enrichment technology enables clinical multiparameter cell sorting,” *PLoS One*, vol. 7, no. 4, e35798, 2012.

Focus Group Neuroscience

Prof. Thomas Misgeld | Hans Fischer Tenure Track Fellow

Rita Förster | Doctoral Candidate

© Prof. Arthur Konnerth, Neuroscience, TUM

Highlights and Achievements



Thomas Misgeld



Arthur Konnerth

From subcellular mechanisms to systems of neurological disease

79

We in the Neuroscience Focus Group have set the aim to use systemic approaches in neuroscience to advance our understanding of how brain circuits work, and how they suffer in disease. Our approach is to combine optical, physiological and morphological techniques to study nerve cells *in vivo* in the nervous systems of model vertebrates, such as mice or zebrafish. Previous years have seen major efforts to push technology to the limit of what optical resolution can afford. These labors are epitomized in the Konnerth lab's achievement of visualizing the activity of single neuronal contact sites, a.k.a. synapses, *in vivo* (e.g. summarized in Grienberger & Konnerth (2012)) and the Misgeld lab's success in studying to role of organelles such as mitochondria in disease (e.g. Marinković et al., PNAS 2012). In 2012 we have now taken efforts to advance from the very small towards the “systemic” level. Instead of single synapses or organelles the focus of studies lies on how the ensemble of such structures operate and relate to higher order aspects of function of dysfunction. For example, we were interested in how neuronal networks of defined function respond to neurodegenerative challenges, or how the entirety of all mitochondria behaves in a single cell when faced with degenerative insults.

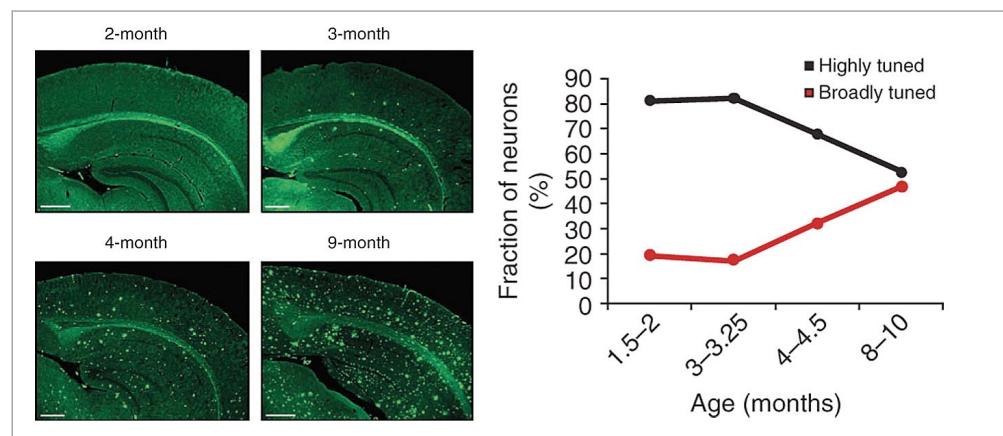

1 | Nature Communications, 2012, Konnerth lab
On the left: The increasing burden with aggregated Alzheimer-disease proteins (green dots) can be seen in Alzheimer-disease mice of increasing age.

On the right: The degree to which single neurons respond well (“highly tuned”) or poorly (“broadly tuned”) to specific orientations of visual stimuli.

The Konnerth lab has taken advantage of a well-established Alzheimer model in mice to ask how the activity patterns of neurons in the parts of the cerebral cortex that processes visual information change in early stages of the disease process (Grienberger et al., Nature Comm. 2012). By following the calcium levels in these cells that correlate with activity, they managed to measure the *in vivo* response of single neurons to visual stimuli of a certain orientation - normally many nerve cells in the visual cortex show a well-defined preference for one orientation or another. Not so in early stages of the Alzheimer model - the cells' response preference become smudgy and less stringent, probably meaning that the circuit's ability to “recognize” directionality weakens. Would this mean that such mice have a harder time to recognize and respond to stimuli of a certain direction? (A mouse does care - just imagine an

ominous raptorial shadow approaching from the front or the side...) This can be tested by asking mice - which swim quite well - to use visual cues of specific orientation to find a hidden platform in a bath of milky water. And indeed, Alzheimer mice need much bigger differences of orientation to know where a platform is hidden

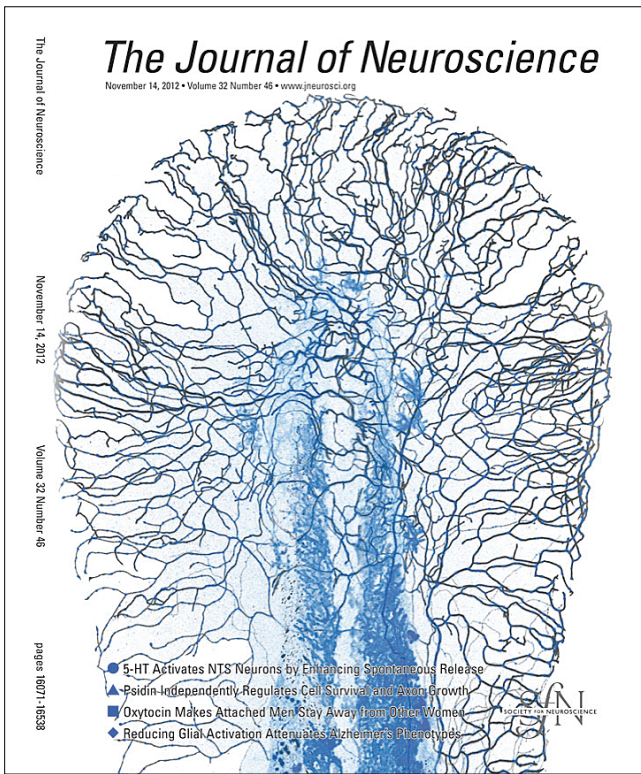

2 | Cover of the Journal of Neuroscience, November 2012, Misgeld lab. Shown is a micrograph of the tail of a zebrafish larva, with nerve processes shown as black lines and neuronal mitochondria as blue dots.

than their non-diseased peers. Hence, the Konnerth lab could show that a cellular readout of circuit function can be directly correlated with a systemic behavioral deficit - analogues of which are well known from human dementia patients.

While the Konnerth lab's work focused on how to integrate single-cell activity in the systemic context of circuits and behavior, the Misgeld group studied how the dynamism of a certain organelle - energy-producing mitochondria - plays out in the entirety of processes that a neuron forms. While mitochondrial dynamics are widely studied in cells isolated from the organism, few studies have so far succeeded to follow such dynamism in neurons that exists in their natural context. Indeed, this is not easy to do, as neurons form very extensive processes, and few animals allow imaging such cells in their entirety.

The zebrafish is an exception, as its larval stages are almost transparent, and the sensory neurons innervating its skin are arranged in a nearly two-dimensional

sheath. Taking advantage of this, the Misgeld lab has succeeded in marking mitochondria in zebrafish and imaging them as sensory neurons grew and differentiated (Plucińska et al., *J. Neurosci.* 2012). In collaboration with the group of Prof. Christian Haass and Dr. Bettina Schmid at LMU Munich, Prof. Thomas Misgeld and colleagues used this new model to study how mitochondrial dynamism is disrupted when nerve cells are confronted with an Alzheimer-related protein - tau - that binds to the cytoskeleton. By modulating biochemical pathways that alter the strength with which tau binds the cytoskeleton, the Misgeld and collaborators could show that such transport deficits can be corrected.

In addition to these scientific high-lights, the Neuroscience Focus Group had further progress to report in 2012: Both Prof. Arthur Konnerth and Prof. Misgeld became principle investigators in a new Cluster of Excellence, the "Munich Cluster for Systems Neurology" (SyNergy), which was established as part of the second round of the German "Excellence Initiative". With Prof. Misgeld as co-coordinator, this Cluster's concept is heavily influenced by the "systems neuroscience" approach of the TUM-IAS Neuroscience Focus Group. In addition to this, the "Center of Integrated Protein Science Munich" (CIPSM) also received renewal funding - with Prof. Konnerth as coordinator of one Focus Group and Prof. Misgeld as associated PI. Prof. Konnerth was awarded a European Research Council (ERC) Advanced Grant, one of the most prestigious research awards in Europe. Prof. Misgeld received tenure at TUM in 2012, which successfully completed the "tenure track" process that was initiated by TUM-IAS in 2007. Further, he was appointed as associate member of the German Center of Neurodegenerative Diseases Munich and was awarded the Alzheimer Research Award of the Hans und Ilse Breuer Foundation.

Selected Publications

- [1] C. Grienberger and A. Konnerth, "Imaging calcium in neurons," *Neuron*, vol. 73, no. 5, pp. 862-85, 2012.
- [2] C. Grienberger, N. L. Rochefort, H. Adelsberger, H. A. Henning, D. N. Hill, J. Reichwald, M. Staufenbiel, and A. Konnerth, "Staged decline of neuronal function in vivo in an animal model of Alzheimer's disease," *Nature Comm.*, vol. 3, 774, 2012.
- [3] G. Plucińska, D. Paquet, A. Hruscha, L. Godinho, C. Haass, B. Schmid, and T. Misgeld, "In vivo imaging of disease-related mitochondrial dynamics in a vertebrate model system," *J. Neurosci.*, vol. 32, no. 46, pp. 16203-16212, 2012.
- [4] P. Marinković, M.S. Reuter, M.S. Brill, L. Godinho, M. Kerschensteiner and T. Misgeld, "Axonal transport deficits and degeneration can evolve independently in mouse models of amyotrophic lateral sclerosis," *Proc. Natl. Acad. Sci. USA*, vol. 109, no. 11, pp. 4296-4301, 2012.

Nanoimprint and Nanotransfer

Molecular Aspects in Interface Science

Nanophotonics

Nanoscale Control of Quantum Materials

Focus Group **Nanoimprint and Nanotransfer**

Prof. Khaled Karrai | Rudolf Diesel Industry Fellow

Prof. Wolfgang Porod | Hans Fischer Senior Fellow

82 Highlights and Achievements



Khaled Karrai



Wolfgang Porod

Towards cost-effective nanofabrication techniques

Nanoimprint techniques have been developed in recent years with the motivation of providing an alternative to optical lithography for the realization of silicon-based integrated circuits. An important challenge posed by compatibility with IC fabrication technology is the need for alignment on the nanometer scale over several layers, which can only be met if novel alignment methodologies are developed for nanoimprinting. Our work, in collaboration with attocube systems AG, has addressed this critical issue. In addition, our work has contributed to a variety of new applications, which have emerged in a variety of fields, such as bioelectronics, sensors, and nanofabrication. The aim of the focus group is to demonstrate that nanoimprint lithography and nanotransfer are indeed valuable techniques for nanofabrication, in particular when low-cost and large-scale processes are required.

We have recently demonstrated that nanoimprinting is a valuable alternative to electron-beam lithography for patterning Silicon substrates and thus provide templates for the growth of InAs nanowires via Molecular Beam Epitaxy. In addition, we have shown that conductive films made either with metals or conductive polymers can be patterned in order to alter the film optical properties. In previous work, we have demonstrated that entire functional nanometer scale devices can be produced with such nanoimprint and nanotransfer techniques. More specifically, we have demonstrated the transfer of arrays of metal-oxide-metal and metal-metal structures as rectifying elements in large-scale nanoantenna arrays for infrared detection and/or energy harvesting. Over this past year, we were able to elucidate the physical mechanism at work for IR detection, and we were able to show that the heating caused by the radiation-induced antenna currents gives rise to a thermoelectric response, which provides the detector signal. Part of this work was performed while TUM-IAS supported doctoral candidate Mario Bareiss visited the group of Prof. Wolfgang Porod at the University of Notre Dame.

In a related effort, patterning via nanoimprinting has allowed us to fabricate nanomagnets, which in turn are the building block of a new class of circuits based on magnetic field coupling. This activity on nanomagnet logic (NML) is part of a research project (sponsored by DARPA) that also includes, among others, the University of Notre Dame, the University of California at Berkeley, and IBM. In recent developments, we have successfully demonstrated nanoimprint lithography for the patterning large-scale arrays of nanomagnet majority-logic gates and a full adders (see image below). The stamps for the imprinting process were made by the company IMS Chips in Stuttgart. The processing of the imprinted samples was performed by TUM-IAS-supported doctoral candidate Muhammad Atyab Imtaar while he visited the group of Prof. Porod at the University of Notre Dame.

One central component of a cost-effective nanofabrication technique, such as nanoimprint transfer, is to be able to precisely and reliably reposition a wafer or a stamp for multiple imprint processes. This requires the development of a position sensing technology that is cost-effective while reaching very high positioning resolution and this in the sub nm range. During the past years with the help of attocube systems AG

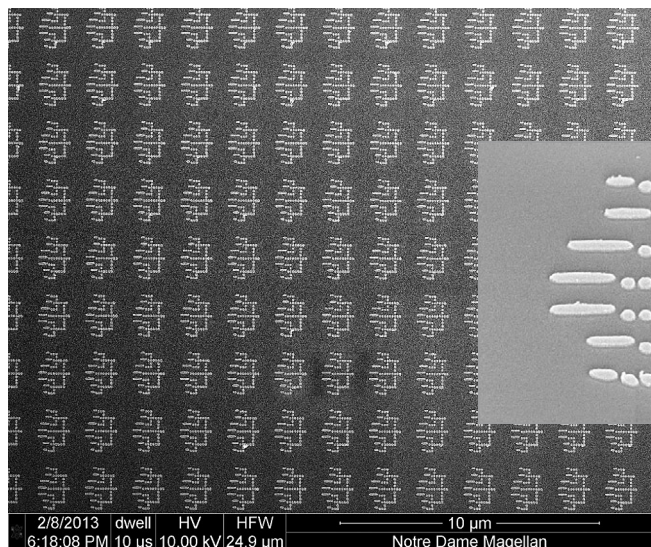

1 | The micrograph above shows an array of nanomagnet adder structures fabricated by imprinting followed by permalloy deposition and lift-off. The inset shows a magnified single adder structure.

we have worked on a developing an interferometric position and displacement sensor. The multiple channel sensor is entirely based on optical fiber technology operating at telecom wavelength as to keep its costs relatively low while maintaining very high specifications. In the last Annual Report we reviewed the essential characteristics of this sensor in terms of bandwidth, range, sensitivity, accuracy compactness and repeatability which where all unique for such a compact system. This year we have pushed the characterization of such a system in terms of its immunity against long terms drifts. We have organized an experiment that maintained by design a drift free constant distance between the miniature sensor head and a mirror target, while monitoring the readout for fluctuation and drift. The experiment involved cooling the sensor head and the target mirror placed at about 20 mm from the sensor. The temperature of 4 Kelvin is low enough that no significant thermal expansion and thermal drift is expected from the sensor/target system. In such a situation all the measured readout drift and fluctuation is intrinsic to the interferometer.

Selected Publications

- [1] M. Bareiß, F. Ante, D. Kälblein, G. Jegert, C. Jirauschek, G. Scarpa, B. Fabel, E. Nelson, G. Timp, U. Zschieschang, H. Klauk, W. Porod, and P. Lugli, "High-yield transfer printing of metal-insulator-metal nanodiodes," *ACS Nano*, vol. 6, no. 3, pp. 2853–2859, 2012.
- [2] M. Bareiß, D. Kälblein, C. Jirauschek, A. Exner, I. Pavlichenko, B. Lotsch, U. Zschieschang, H. Klauk, G. Scarpa, B. Fabel, W. Porod, and P. Lugli, "Ultra-Thin Titanium Dioxide," *Applied Physics Letters*, vol. 101, no. 8, p. 083113, 2012.

The data were recorded over 14 hours on a row as shown in the figure below. The results were remarkable and showed no measurable drift and a readout fluctuation with a two sigma variance of 286 pm in a bandwidth of 100HZ. The same experiment showed that the noise readout increases with the distance between the sensor head and the target, namely a two sigma variance of 530 pm for a distance of 50 mm and 1.0 nm variance for a distance of 100mm.

This behavior is expected from the slight wavelength fluctuation in the 0.010 ppm range. This shows that the remarkable specifications for these interferometric readout systems are absolutely drift-free and at this point, more than enough for our project when operating under vacuum. The next steps of correction required are those induced by variable air pressure, temperature, and humidity. Such variations can be held at constant levels by operating under controlled atmosphere. Another important benchmark was the verification that the system could track a target displacement at velocities approaching the meter per second. We have indeed reached a reliable position tracking at 0.8 m/s which opens up the way to increase the throughput in nano-transfer and nano-imprinting in device fabrication.

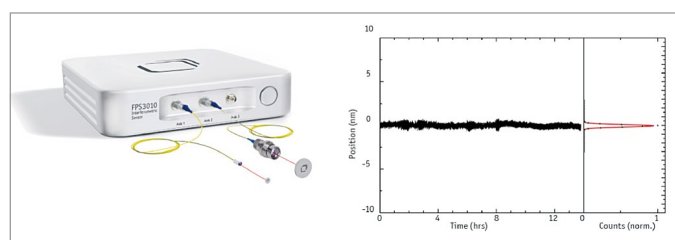

2 | Right: Determination of drift and fluctuation of a position fiber-based interferometric sensing over a time span of 14 hours. There is virtually no drift to be seen and the position readout fluctuation corresponds to a two sigma variance of 286 pm in a bandwidth of 100Hz for a target distance of 20 mm. Left: the three channels all fiber based interferometer (attocube systems AG)

84 Highlights and Achievements



Julia Kunze-Liebhäuser

Electrochemistry research in energy conversion and storage – from fundamentals to nanotechnology application

Our research focuses on interface science where we investigate the properties of two adjacent condensed phases which are important for a fundamental understanding of energy conversion and storage phenomena that find application in electrocatalysis and battery research.

Novel material systems for electrocatalysis in fuel cells

Conductive TiO_xC_y [1] is used as support for catalyst nanoparticles and investigated towards the oxygen reduction reaction (ORR) and the ethanol oxidation reaction (EOR). The development and study of innovative catalyst supports other than carbon is necessary to improve the (electro)chemical stability and catalytic activity in the positive potential range that is applied during ORR. We synthesize and study titanium oxycarbide (TiO_xC_y) supported Pt nanoparticles to understand how the stoichiometry and morphology of the TiO_xC_y support material affects the activity and stability of Pt/ TiO_xC_y towards the ORR by employing surface science techniques in close combination with the so-called thin film rotating ring disk method. With this approach, not only activity and stability can be determined but also the amount of intermediate reaction products can be identified, which will help us to fundamentally understand the processes occurring at the solid/liquid interface. We also investigate the electrocatalytic activity and stability of catalysts (Pt and group six metal carbides) supported on TiO_xC_y model substrates, such as reduced rutile TiO_2 single-crystals and converted flat and nanotubular anodic films, towards the EOR at elevated temperatures. The electrochemical measurements at elevated temperatures are performed in a specific electrochemical cell that can be used up to temperatures of 150°C under ambient pressure. Our first findings indicate that TiO_xC_y is a potential candidate to replace carbon as a support for use in direct ethanol fuel cells.

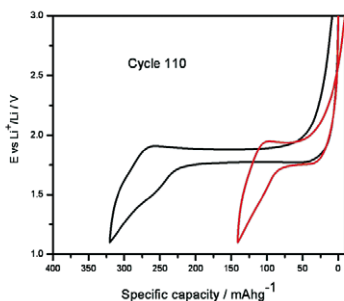

1 | Galvanostatic charge-discharge curves (cycle 110) of anatase TiO_2 nanotubes annealed in $\text{C}_2\text{H}_2/\text{Ar}$ (black curve) and in pure Ar (red curve) in 1 M LiPF_6 in ethylene carbonate/dimethyl carbonate (EC/DMC) (1:1); C-rate: 50 mA g^{-1} (0.3 C); counter electrode: Li, reference electrode: Li.

TiO_2 and TiO_xC_y -based anode materials for lithium-ion intercalation

Nanostructured TiO_2 materials, which are thermally reduced to TiO_x and TiO_xC_y , are used as anodes for lithium ion intercalation. The charge and discharge characteristics are analyzed electrochemically, and the processes at the solid/liquid interface, the crystallographic structure, the chemistry of the surface, and the surface potential during intercalation are investigated using surface science tools. First Li-intercalation experiments were conducted with anatase TiO_2/C composite nanotubes. Galvanostatic measurements revealed very promising reversible storage capacities of $\sim 320 \text{ mAh g}^{-1}$ at a rate of 50 mA g^{-1} (0.3 C) (see figure 1) and of $\sim 155 \text{ mAh g}^{-1}$ at a rate of 1 Ag^{-1} (6.0 C). These findings show that full lithiation of nanostructured reduced anatase TiO_2 is possible and that the material has a very high rate capability [2].

In collaboration with doctoral candidates Jassen Brumbarov, Silvia Leonardi, and Rianne Schöffler.

Selected Publications

- [1] C. Rüdiger, F. Maglia, S. Leonardi, I.D. Sharp, O. Paschos, and J. Kunze, "Surface analytical study of carbon-thermally reduced titania films for electrocatalysis application," *Electrochim. Acta*, vol. 71, pp. 1–9, 2012.
- [2] P. Vivek, S. Leonardi, and J. Kunze, "Oxygen deficient, carbon coated self-organized TiO_2 nanotubes as anode material for Li-intercalation," in preparation.

Focus Group Nanophotonics

Prof. Gerhard Abstreiter | Carl von Linde Senior Fellow

Stefan Funk, Sara Yazji | Doctoral Candidates

Dr. Eric Hoffmann | Postdoctoral Researcher

© Experimental Semiconductor Physics, TUM

Highlights and Achievements



Gerhard Abstreiter

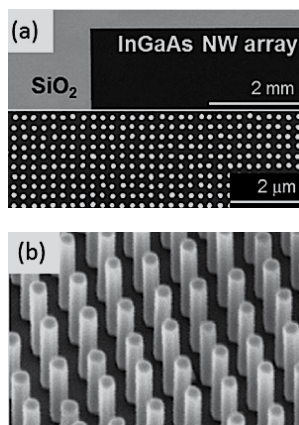

1 | (a) Photograph (upper panel, black area) and corresponding top-view scanning electron microscope (SEM) image (lower panel) of an InGaAs nanowire array grown site-selectively on SiO₂/Si (111). The density of this array is 1.6 billion nanowires per cm².

(b) Close-up of an SEM image in bird's eye view (tilt angle 70°) of the same nanowire array. [1]

Semiconductor hetero-nanowires on Si for nanoelectronics, nanophotonics and photovoltaics 85

Within our Nanophotonics Focus Group we aim to integrate III-V semiconductor nanostructures (GaAs and InAs based) in conventional Si technology with respect to photonic applications on a Si platform. This hybrid approach is normally not possible due to the large lattice mismatch of the materials involved, which causes many defects. However, this problem can be overcome by site-selective hetero-epitaxy of nanowires where the lattice mismatch is relaxed elastically due to the small footprint on Si.

Our goals are:

- Fabrication and characterization of high quality III-V nanowires on Si
- Up-scaling to high density and large area ordered arrays of nanowires on Si
- Demonstration of novel hetero-nanowire quantum-devices
- Development of new generation photo-detector and photovoltaic devices with strongly enhanced quantum efficiency

In the past year we have greatly improved homogeneity control of composition-tuned In_{1-x}Ga_xAs (x<0.4) nanowire (NW) arrays grown by catalyst-free molecular beam epitaxy (MBE) on nano-imprinted SiO₂/Si (111) substrates (see [1] and figure 1). Structural and optical characterization of these NW arrays demonstrate the excellent potential of site-selective MBE growth of high-periodicity non-tapered In_{1-x}Ga_xAs NWs with low size and composition dispersion for optimized device integration on Si. Such arrays have high potential for photovoltaic devices with strongly enhanced efficiencies. First devices have been fabricated and are at present in the test phase.

We have also investigated the effect of various parameters on the room-temperature interband tunneling characteristics of intrinsically n-type In_{1-x}Ga_xAs NWs on p-type Si substrate using conductive atomic force microscopy. Large tunnel currents (>40 kA/cm²) and reduced breakdown voltages are obtained by increasing the p-type substrate doping level to >1 × 10¹⁹ cm⁻³ (see [2]). Current mapping under forward bias reveals a bimodal distribution of NW/Si hetero-junction tunnel diodes exhibiting either negative differential resistance (NDR, Esaki diode) or high excess currents. Peak-to-valley current ratios in Esaki-type diodes increase and saturate with maximum values of about 3 by down-scaling the NW diameter from about 90 nm to about 25 nm. These studies are the basis for the development of novel nanowire tunnel transistors which could be integrated into conventional CMOS-technology.

Selected Publications

- [1] S. Hertenberger, S. Funk, K. Vizbaras, A. Yadav, D. Rudolph, J. Becker, S. Bolte, M. Döblinger, M. Bichler, G. Scarpa, P. Lugli, I. Zardo, J. J. Finley, M. C. Amann, G. Abstreiter, and G. Koblmüller, "High compositional homogeneity in In-rich nanowire arrays on nanoimprinted SiO₂/Si(111)," *Applied Physics Letters*, vol. 101, no. 4, pp. 043116/1–5, 2012.
- [2] T. Yang, S. Hertenberger, S. Morkötter, G. Abstreiter, and G. Koblmüller, "Size, composition, and doping effects on In(Ga)As nanowire/Si tunnel diodes probed by conductive atomic force microscopy," *Applied Physics Letters*, vol. 101, no. 23, pp. 233102/1–5, 2012.



Willi Auwärter

Molecular functionality and self-assembly on advanced substrates

During the last year, we broadened and deepened our understanding of single molecule processes on surfaces. Currently, we are aiming at the controlled assembly and comprehensive characterization of molecular nanostructures on advanced substrates as atomically thin sp^2 -bonded layers.

Here are two highlights. First, we introduced a four-level conductance switch which is based on the transfer of a single proton, thus representing the smallest possible atomistic switching unit [1]. To this end, we applied a porphyrin molecule anchored on a smooth silver contact as functional tecton that hosts two hydrogen atoms in its central pocket. After deliberately removing one of these hydrogens, the remaining one can occupy four distinct positions within the porphyrin macrocycle. A current applied by the atomically sharp tip of a scanning tunneling microscope under controlled ultra-high vacuum conditions is used to translate the proton between the four positions. Each position is characterized by a distinct conductance through the molecular junction.

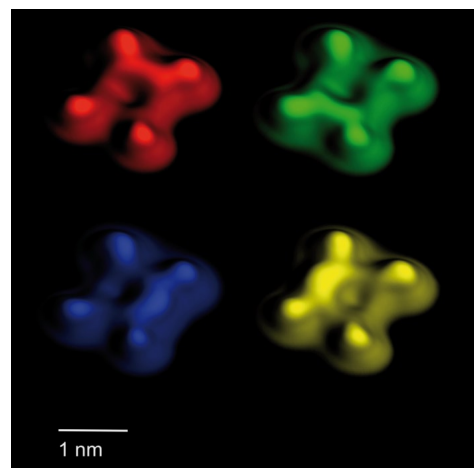

1 | STM images of an individual porphyrin molecule on a silver substrate. The different colors represent the four states of the conductance switch, characterized by the position of the central hydrogen atom.

In a second example, we grew and comprehensively characterized atomically thin boron nitride layers on a copper support. Films of boron nitride have recently attracted considerable interest because of their large band gap, a potential implementation in graphene nanodevices and their use as spacer layers to electronically decouple functional adsorbates. Our research evidenced an electronic superstructure in these sp^2 -bonded sheets exhibiting very large periodicities [2]. Combined with its insulating properties, this makes boron nitride on copper unique. Preliminary experiments reveal that the system indeed represents an ideal platform for nanoscale assemblies. Our future efforts will concentrate on the deliberate tuning of functionalities of single molecules and the self-assembly of supramolecular architectures on ultra-thin textured boron nitride layers. Specifically, a control on reactivity and magnetic properties in such systems is of great interest.

Selected Publications

- [1] W. Auwärter, K. Seufert, F. Bischoff, D. Ecija, S. Vijayaraghavan, S. Joshi, F. Klappenberger, N. Samudrala, and J. V. Barth, "A surface-anchored molecular four-level conductance switch based on single proton transfer," *Nature Nanotechnology*, vol. 7, pp. 41–46, 2012.
- [2] S. Joshi, D. Ecija, R. Koitz, M. Ianuzzi, A.P. Seitsonen, J. Hutter, H. Sachdev, S. Vijayaraghavan, F. Bischoff, K. Seufert, J.V. Barth and W. Auwärter, "Hexagonal boron nitride on Cu(111): an electronically corrugated monolayer," *Nano Lett.*, vol. 12, pp. 5821–5828, 2012.

Fundamentals of Science and Technology

87

Fundamental Physics

Nonequilibrium Statistical Mechanics at
the Nanoscale

Fiber-Optic Communication and
Information Theory

Focus Group Fundamental Physics

Prof. Gino Isidori | Hans Fischer Senior Fellow

Prof. Stefan Pokorski | Hans Fischer Senior Fellow

Emmanuel Stamou | Doctoral Candidate

88 Highlights and Achievements



Gino Isidori

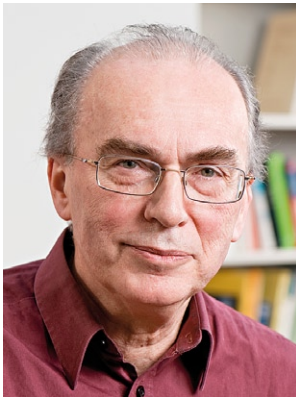

Stefan Pokorski

Fundamental physics after the Higgs discovery

The most important highlight in Fundamental Physics in 2012 was the discovery of a “new” particle at the Large Hadron Collider (LHC) at CERN. Its mass of 125 GeV and its various properties indicate that this could be the Higgs particle, the last element of the Standard Model (SM) of particle physics. Whether this is indeed the Higgs particle of the SM or a new particle belonging to an even grander theory remains to be seen once more data is collected and the statistical and systematic errors are reduced. But it looks as though the present theory of elementary particle physics is on the right track towards an ultimate theory of elementary particles and their interactions

The discovery of the Higgs particle itself did not provide answers to several outstanding questions, in particular regarding the origin of the matter-antimatter asymmetry observed in the universe that is essential for our existence. Similarly the observed vast hierarchies in the masses of elementary particles, quarks and leptons and the hierarchies in their mutual interactions are not explained by this discovery. In order to address such questions the SM has to be generalized to a more powerful theory that contains new heavy particles, beyond the known quarks and leptons and/or new forces beyond the electroweak and strong interactions present in the SM. Unfortunately, until now no convincing signs of new heavy particles and new forces have been seen in high-energy collisions at the LHC, even if this collider already explores short distance scales as short as 10^{-19} m. Fortunately, there exists at present a second route to explore the short distance scales by means of very rare decays of the so-called B-mesons that are governed by quantum fluctuations. These phenomena are studied by the LHCb experiment at CERN, and the year 2012 also brought new results here, to be reported below.

The research in the Focus Group Fundamental Physics primarily follows the second route to shorter distance scales by exploring the flavor physics that is the physics describing different kinds (flavors) of leptons and quarks, their flavor violating interactions and their masses. With these methods short distance scales as short as 10^{-20} m, which is beyond the reach of the LHC, can be explored, possibly discovering new particles and new forces in an indirect manner.

In this context our group has already performed detailed analyses of various extensions of the Standard Model of particle physics identifying patterns of flavor violation and correlations between various observables for several years; these will allow us, with the help of further future precise experiments, to uncover what kind of dynamics, new interactions and new particles exist at the scales of order 10^{-20} m and even short distance scales. These activities have been intensified in 2011 through the ERC Advanced Grant awarded to Prof. Andrzej Buras. The main goal of this project is the construction of the fundamental theory of flavor. Its start was in May 2011 and will continue until April 2016, being dominantly performed in the TUM-IAS building. In addition to the project leader (Prof. Buras) and his group of postdoctoral researchers, the two Hans Fischer Senior Fellows Prof. Gino Isidori and Prof. Stefan Pokorski are actively involved in this expedition towards the shortest distance scales.

The highlights of our research in 2012 can be summarized as follows:

One of the important rare decays explored by the LHCb is the decay of the B_s meson into a pair of leptons (muons). This decay is very strongly suppressed within the SM so that only one in every 300 million B_s mesons produced by the LHC is expected to decay to a pair of muons. The most accurate calculation of the probability (1 corresponding to 100%) for this decay to occur within the SM performed by us to date was in August 2012, resulting in $(3.2 \pm 0.3) \cdot 10^{-9}$ [1]. In November 2012, LHCb reported the number $(2.9 + 1.4 - 1.1) \cdot 10^{-9}$, fully consistent with our result but in view of large experimental errors still allowing for contributions from new heavy particles beyond the Standard Model.

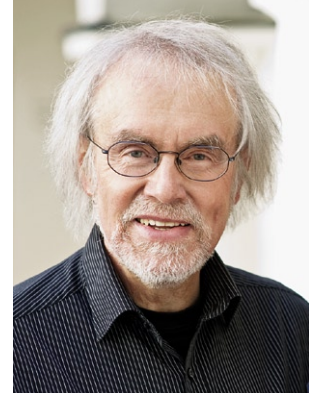

Andrzej Buras

One of the important results of our efforts in 2011 towards the construction of the theory of flavor was the construction of a minimal theory for quark masses. This theory attributes the observed hierarchy in the quark masses to the hierarchy of interactions of SM quarks with new very heavy fermions with masses of order of a few TeV and in the reach of the LHC. While the Higgs particle is present in this framework, it is only responsible for the generation of the masses of SM gauge bosons W and Z and the spontaneous breakdown of the SM gauge symmetry. The observed masses of quarks and their flavor violating interactions are on the other hand generated through the dynamics of new heavy quarks. A detailed analysis of phenomenological implications for flavor physics has been performed during 2012 in [2]. It turns out that the minimal version of this model allows satisfactory description of quark masses and flavor violating processes while making rather specific predictions for rare decays of B_s , B_d and K mesons. In particular we find that for the masses of the heavy fermions of order 3 TeV, the probability for the decay of B_s mesons into a pair of muons amounts to $(4.6 \pm 0.4) \cdot 10^{-9}$, significantly larger than the SM prediction but still consistent with the LHCb data. We are now waiting for the improved data from the LHCb to see whether these new data will confirm our prediction.

In two related works [3] and [4] we investigated the impact of the heavy fermions that arise in the context of flavor symmetries (“flavor messengers”). In [3] we considered supersymmetric flavor models, in which such fields can have important phenomenological consequences even if their mass scale is very large. This is because the flavor violation can leave its imprint on low energy physics through the flavor structure of sfermion masses. We quantitatively estimated this effect for broad classes of flavor models, finding that abelian flavor models are very strongly constrained in such scenarios, even when sfermion masses are assumed to be universal at the high scale. Additionally, in [4] we studied the direct effects of low-energy flavor messengers in a model-independent way. Just using the couplings to SM fermions that must be necessarily present, we derived lower bounds on the messenger scale. While in abelian models this scale must be larger than around 20 TeV, in non-abelian models the messengers can be as light as a TeV, and therefore possibly in the reach of the LHC.

As far as the direct discovery of the Higgs boson is concerned, our group has been involved in two relevant studies. First of all, we have clarified that, with the present value of the Higgs mass, the SM is not absolutely stable up to the Planck scale: the Higgs potential develops a deeper minimum at very high field values (more stable with respect to the “electroweak” minimum, or the field configuration needed to explain the masses of the elementary particles). However, we have also clarified that this observation cannot be translated into an inconsistency of the model, since the “electroweak” minimum has a life time much longer than the age of the Universe [5]. The second analysis we have performed is about possible flavor-violating decays of the Higgs boson: such processes are forbidden within the SM but could provide a clean window on physics beyond the SM. We have demonstrated that, with a Higgs mass around 125 GeV, flavor-violating partial decay rates into a tau-mu or tau-e pair as large as 10% are allowed by present data [6].

Selected Publications

- [1] A. J. Buras, J. Girrbach, D. Guadagnoli, and G. Isidori, “On the Standard Model Prediction for $B_s \rightarrow \mu^+ \mu^-$,” *Eur. Phys. J. C*, vol. 72, no. 10, 2172, 2012.
- [2] A. J. Buras, J. Girrbach, and R. Ziegler, “Particle-Antiparticle Mixing, CP Violation and Rare Decays in a Minimal Theory of Fermion Masses,” arxiv:1301.5498 [hep-ph].
- [3] L. Calibbi, Z. Lalak, S. Pokorski and R. Ziegler, “The Messenger Sector of SUSY Flavour Models and Radiative Breaking of Flavour Universality”, *JHEP* 1206, vol. 018, 2012.
- [4] L. Calibbi, Z. Lalak, S. Pokorski, and R. Ziegler, “Universal Constraints on Low-Energy Flavour Models,” *JHEP07*, vol. 004, 2012. doi: 10.1007/JHEP07(2012)004
- [5] J. Elias-Miro, J.R. Espinosa, G.F. Giudice, G. Isidori, A. Riotto, and A. Strumia, “Higgs mass implications on the stability of the electroweak vacuum,” *Phys.Lett. B*, vol. 709, pp. 222–228, 2012.
- [6] G. Blankenburg, J. Ellis, G. Isidori, “Flavour-Changing Decays of a 125 GeV Higgs-like Particle,” *Phys.Lett. B*, vol. 712, pp. 386–390, 2012.

Focus Group Nonequilibrium Statistical Mechanics at the Nanoscale

Dr. Vladimir García Morales | Carl von Linde Junior Fellow

Lennart Schmidt | Doctoral Candidate

© Prof. Katharina Krischer, Nonequilibrium Chemical Physics, TUM

Highlights and Achievements



Vladimir García Morales

Statistical mechanics of electrochemical nanosystems, cellular automata and complexity

91

Last year we applied our theory of statistical mechanics for nanoscale electrochemical systems to electrochemical oscillators, addressing the question of how the quality of regular, periodic oscillations in the electric current is affected by molecular noise (i.e. by the stochastic character of electron transfer events on nanoelectrodes). These results are being prepared for publication.

By using our macroscopic theory for spatially extended electrochemical oscillators, our doctoral candidate Lennart Schmidt found new exciting dynamical states both theoretically and in his computer simulations. Under purely global coupling, a new kind of chimera state (where order and chaos coexist spatiotemporally) was discovered after a sequence of bifurcations involving subharmonic clustering. Very recently, these spatiotemporal patterns have been also found experimentally in Prof. Katharina Krischer's group. The first papers in the mathematical theory for cellular automata, which provide analytical expressions for all known cellular automata, have already been published [1, 2]. A plethora of new results have been derived from this theory and are being prepared for publication. Perhaps the most exciting ones concern our discovery of a cellular automaton model that allows arbitrarily complex organisms to replicate in an entirely biomimetic way. Information is encoded in the form of a "chromosome", given as initial condition in the form of a finite set of integer numbers between 0 and $p-1$ (with p being an odd prime number). Then a theorem has been proved that establishes that the structure formed by the cellular automaton after $(p-1)/2$ time steps exactly replicates at $p+(p-1)/2$ time steps yielding several copies of itself, in a process that entirely resembles the mitosis of eukaryotic cells. The number of replicas depends on symmetry relationships of the neighborhood employed by the cellular automaton rule. This mathematical mechanism is general and robust and can be used to explain reproduction of complex living organisms in nature.

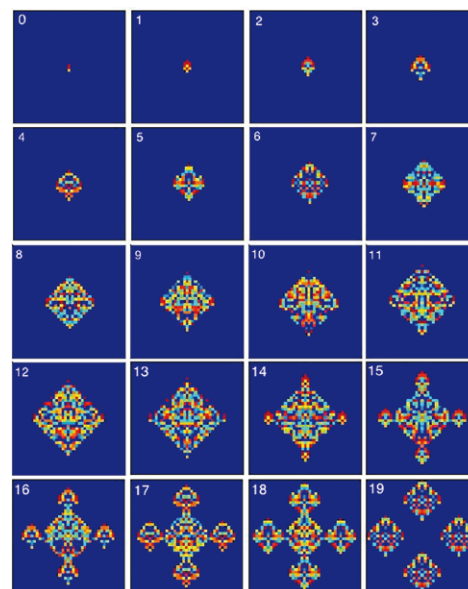

1 | Self-replication of a complex structure. Shown is the time evolution (number of time steps indicated on each panel) of a 2D cellular automaton on a von Neumann neighborhood employing a prime number $p=13$ of different colors. The structure formed at $(p-1)/2 = 6$ time steps produces four copies of itself at $p+(p-1)/2 = 19$ time steps.

Selected Publications

- [1] V. García Morales, "Universal Map for Cellular Automata," *Physics Letters A*, vol. 376, no. 40–41, pp. 2645–2657, 2012.
- [2] V. García Morales, "Symmetry Analysis of Cellular Automata," *Physics Letters A*, vol. 377, no. 3–4, pp. 276–285, 2013.

Prof. Frank Kschischang | Hans Fischer Senior Fellow
 Dr. René-Jean Essiambre | Rudolf Diesel Industry Fellow
 Dr. Luca Barletta, Dr. Mansoor Yousefi | Postdoctoral Researchers
 © Prof. Gerhard Kramer, Communications Engineering, TUM

92 Fiber-optic communications via the Nonlinear Fourier Transform

Optical fibers, thin strands of ultra-transparent silica glass not much thicker than a human hair and spanning many thousands of kilometers, carry the bulk of the world's telecommunications. Optical fibers represent a revolutionary technology that enables, at very low cost, the deployment of high-speed, long-distance communication networks possible, such as the Internet. Due to a rapidly increasing traffic demand, today's fiber-optic networks face a looming “capacity crunch,” which has spurred researchers to try to understand the factors that limit their information-carrying capacity. A consensus is emerging that, among many issues that constrain today's systems, one factor stands out as being the most fundamentally important: fiber nonlinearity.

At the high power densities created by the lasers used in fiber optic transmission, the Kerr effect, which causes changes in refractive index in response to the electric field of a propagating wave, becomes significant. In optical fibers, this phenomenon, along with chromatic dispersion, is described by a partial differential equation known as the Nonlinear Schrödinger (NLS) equation. The problem of determining fundamental limits to optical fiber capacity thus becomes that of understanding how information can be properly encoded for transmission over the NLS channel.

In [1], we have approached this problem by attempting to exploit a remarkable property of the NLS equation, first discovered by V. E. Zakharov and A. B. Shabat in 1972; namely that the NLS equation is “integrable.” The implications of this are profound: it means that the NLS equation possesses a type of “hidden linearity” expressed via a so-called “Lax pair” of differential operators and, furthermore, that the equation is compatible with an infinite hierarchy of conserved quantities.

Our idea is to transmit information by modulating such conserved quantities. More specifically, we propose to encode data in the spectrum of the Lax operator associated with NLS equation. Integrability implies an “isospectral flow,” namely that the spectrum is held invariantly under propagation. In practice, such a flow is remarkably stable, even when perturbed by small amounts of noise. The spectrum is revealed by the Nonlinear Fourier Transform (NFT), which can be seen as a nonlinearity-compatible generalization of the classical Fourier transform. By encoding information in the non-interacting signal degrees-of-freedom under NLS propagation, this new method does not suffer from the deterministic cross-talk between signal components which has plagued prior approaches. Although this work is still in its infancy, it has already attracted significant attention from both the academic and industrial research communities.

Selected Publication

[1] M. I. Yousefi and F. R. Kschischang, “Information Transmission using the Nonlinear Fourier Transform, Parts I-III,” submitted for publication.



Frank Kschischang

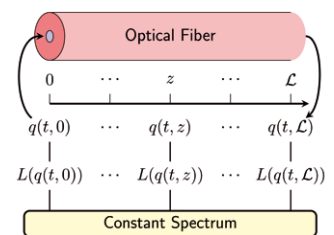

1 | Illustrating an isospectral flow. Although the signal $q(t, z)$ at time t and distance z along the fiber propagates in a complicated way according to the NLS equation, the spectrum of the associated Lax operator L remains invariant.

The TÜV Süd Stiftung Visiting Professor Program

TUM-IAS is very grateful to TÜV Süd for sponsoring an ambitious Visiting Professors Program. At the tune of 50 k€ per year, TUM-IAS is allowed to propose guest professors to visit both TÜV Süd and TUM-IAS, give a number of lectures, engage in research with a TUM group, and otherwise enhance our scientific and technological environment by their knowledge and advice. The professors chosen should, of course, satisfy the requirements of excellence of our Institute, and bring in a field of expertise that is of common interest of both our institutions (there are many such in almost any area of endeavor at TUM, ranging from technical issues e.g. in civil and mechanical engineering, mathematical methods in statistical and risk analysis, issues of general societal importance such as mobility, energy distribution, handling of resources and ecology, up to economic and management questions.) TUM-IAS sets up a competition for these visiting professorships yearly, with the TUM community invited to propose new guest professors. After approval of the selection by our President, the potential candidates who meet the common requirements are proposed for approval to TÜV Süd, which then agrees on the final choice. A short description of the candidates selected in 2012, Prof. Armen Der Kiureghian of the University of California at Berkeley, and Dr. Josef Oehmen of MIT, Boston, is presented next.

Prof. Armen Der Kiureghian, who holds the Taisei Chair in Civil Engineering at the University of California at Berkeley, was a 2012 TÜV Süd Stiftung Visiting Professor at TUM-IAS during September and October 2012. He was hosted by Prof. Daniel Straub and the TUM-IAS Focus Group Engineering Risk Analysis.

His TÜV Süd Stiftung Visiting Professorship gave Prof. Der Kiureghian the chance to meet and interact with a number of TUM-IAS members as well as TUM students and faculty members in various settings. At TUM-IAS he held a two-day workshop in collaboration with Prof. Straub on “Structural Reliability, Risk Assessment and Decision-Making: Past, Present, Future” which brought together 17 international speakers, among them TUM-IAS Rudolf Diesel Industry Fellow Dr. Chin Man W. Mok, and more than 35 participants.

At an evening of discussion at the Oskar von Miller Forum with TUM students, a broad variety of topics were discussed, such as risk analysis, the value of life, earthquake engineering issues or higher education in the United States. However, Prof. Der Kiureghian was also able to meet with engineers from several Munich-based companies, such as the head of the Earthquake Risk Division of Munich Re or Dr. Armin Pfoh of the VP Corporate Innovation Management at TÜV Süd. Focusing on a completely different subject area, he visited the Institute of Near and Middle Eastern Studies at Ludwig-Maximilians-University, where he spoke about the work of his father, Sumbat Der Kiureghian, who was a famous Iranian watercolor artist, in a lecture on “Isfahan, New Julfa and the Art of Sumbat.”

Dr. Josef Oehmen, who is currently a Research Scientist at the Massachusetts Institute of Technology (MIT), was a TÜV Süd Stiftung Visiting Professor from October–December 2012. He was hosted by Prof. Udo Lindemann from the TUM Institute of Product Development.

During his stay, Dr. Oehmen proved to be an active member of the TUM-IAS and TUM community. Next to a talk at the Fellows' Lunch, he participated in the TUM-IAS lecture series "Science and Society – Meet with Excellence," talking about "How I learned to stop worrying and love Fukushima – Zur Kommunikation großtechnischer Risiken und Chancen" (Communicating Risks and Opportunities of Large-Scale Engineering Systems). Furthermore, he also held a graduate course on "Publishing in Engineering Journals" and was invited by the Student Union on "Going Global – International experiences after your undergraduate at TUM."

While being a Visiting Professor, Dr. Oehmen also had the chance to speak at several other institutions, such as the Universität der Bundeswehr, the École Polytechnique Fédérale de Lausanne, TÜV, EADS or Siemens, and to participate in conferences both in Germany and abroad. Regular discussions with doctoral candidates from the Institute of Product Development have led to a number of papers on aspects of lean management, the relationship of risk management and adaptability, as well as the role of risk management in the system architecture, six of which have already been published or submitted for publication.



In Focus DNA Nanotechnology

Excerpts from an interview on January 29, 2013

Patrick S. Regan

98



Within the TUM-IAS Biophysics Focus Group, hosted by Prof. Andreas Bausch in the TUM Physics Department, one line of research is bending DNA toward new ends – that is, exploring how DNA can be used as a programmable building material for self-assembly of nanoscale structures and devices. Broader than the design approach popularly known as “DNA origami,” the field of molecular self-assembly with DNA has seen recent progress justifying a more industrial-sounding handle: “DNA nanotechnology.”

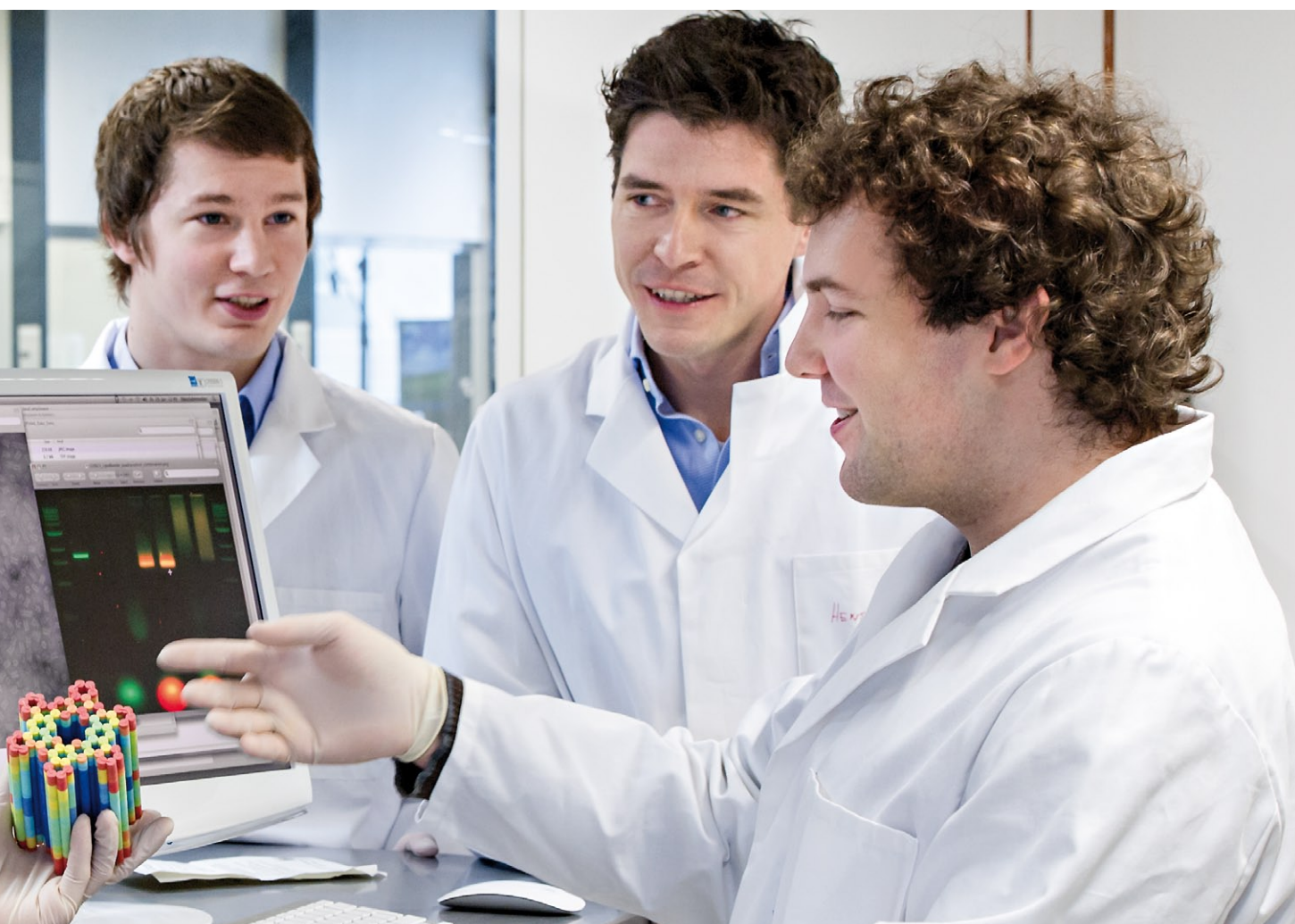

Prof. Hendrik Dietz, a Hans Fischer Tenure Track Fellow of the TUM-IAS, leads the Laboratory for Biomolecular Nanotechnology, which receives additional support from the Excellence Clusters CIPSM (Center for Integrated Protein Science Munich) and NIM (Nanosystems Initiative Munich), the collaborative research center Forces in Biomolecular Systems (DFG SFB 863), the European Research Council, and the Chemical Industry Fund. Dietz's lab works closely with partners at MIT, the MRC Laboratory of Molecular

Biology in Cambridge, England, and the TUM research groups of Prof. Matthias Rief, Prof. Friedrich Simmel, and Dr. Ulrich Rant, a TUM-IAS Fellow and group leader at the Walter Schottky Institute. Four members of the lab met with interviewer Patrick S. Regan (PSR) to look back over a remarkably productive year and consider prospects for the future: Prof. Hendrik Dietz (HD) and doctoral candidates Thomas Gerling (TG), Thomas Martin (TM), and Jean-Philippe Sobczak (JPS).



PSR: Hendrik, you've described the aim of your research as gaining access, through technology, to a domain where nature employs special kinds of mechanical structures to accomplish chemical and biological processes. Could you please elaborate on that?

HD: Every biological cell contains thousands of macromolecules that have well defined three-dimensional shapes, with absolute dimensions on scales from a few to a few tens of nanometers and with atomically precise features. Most commonly these objects are known as proteins. People typically don't appreciate how wonderful these objects are and what they can accomplish, but they are our inspiration.

Proteins are built according to genetic information, and they're made from amino acid chains. The sequence of these amino acid chains already fully encodes the three-dimensional shape that these objects will adopt in solution. Once this shape has been formed, through a self-assembly process, it can already be functional. And the functions range from making new molecules from smaller ones, or breaking down larger molecules, to transport on a nanometer scale, conversion of energy from light into chemical compounds, or even a kind of computation. And basically all of this makes cells live, and enables us to live.

In a way this is nanotechnology that has emerged through evolution. We can look at this in awe and say how wonderful these objects are, and we may want to learn how to actually build something with similar capabilities. But these objects are smaller and more structurally intricate than anything we can build with state-of-the-art top-down fabrication methods. On the other hand, they are far bigger and structurally more complex than anything we can make with state-of-the-art bottom-up chemical synthesis. So really these objects are in a gap, a technology gap, where we haven't yet learned to build with this sophistication.

Nature uses an interesting principle to build these objects, and that's exactly what we want to learn. Using another kind of macromolecule, DNA, we want to learn how to tailor the sequences of biomolecular building blocks so that they already encode a well



defined three-dimensional shape; and ideally the shapes that we build that way could be as complex and as sophisticated as the shapes of these natural macromolecular machines that we find in our cells. Ideally one day we will also be able to encode sophisticated functionality in these shapes. DNA nanotechnology gives us access to this regime between state-of-the-art top-down and bottom-up approaches.

PSR: Thinking about your own inspiration and motivation, do you have favorite examples of nature's biomolecular nanomachines?

HD: ATP synthase. It's a nanoscale rotary motor.

TG: The flagellum motor, that's my favorite machine.

TM: Ion channels are also good. The way they selectively let through some ions and block others, that's pretty amazing.

JPS: I wouldn't say I have a favorite one, but always, when my family asks what I do, what are these molecules good for, I explain that almost everything is made in some way from proteins. Everything in this room for example, like the wood for the desk, the plastic, the paper, the material of your pants, everything was in some part made by proteins. They always want some kind of specific example, but it's easier to point to things that aren't, because there's only a few.

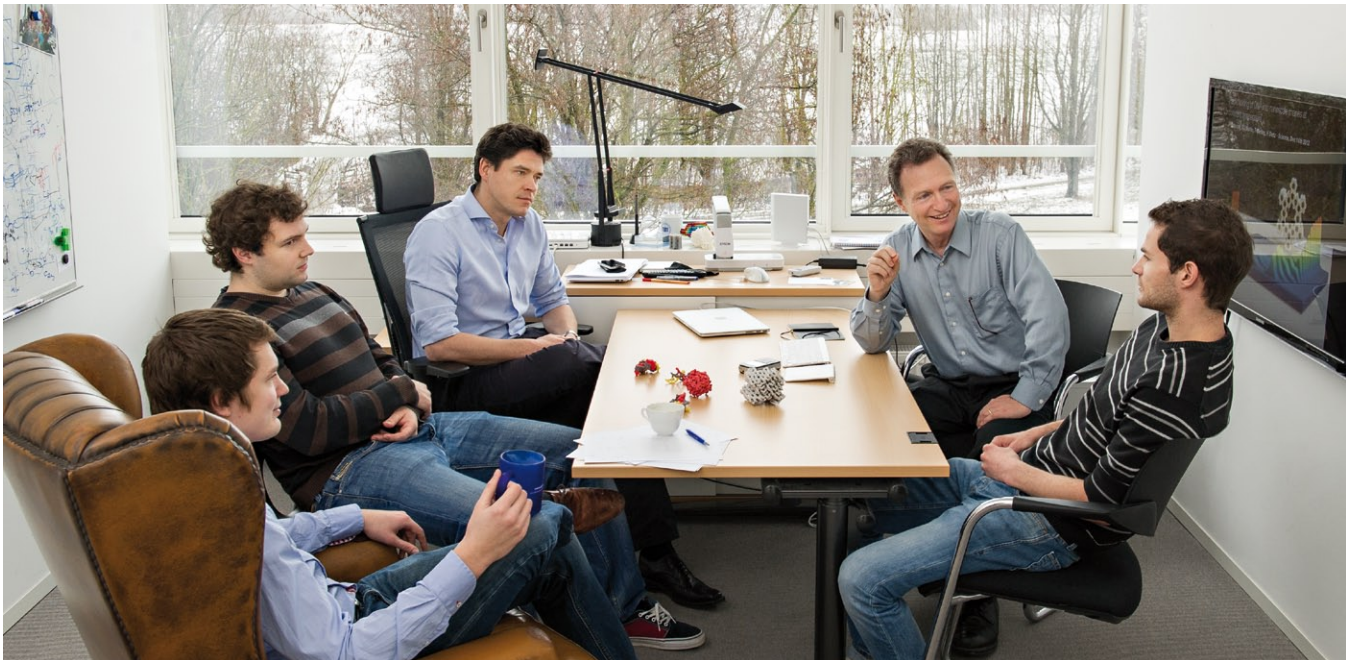

Left to right: Jean-Philippe Sobczak, Thomas Martin, Hendrik Dietz, Patrick Regan, Thomas Gerling

PSR: For building with DNA, what are the basic principles and methods?

HD: The building block is double-helical DNA domains, which we consider a secondary structural unit. Let me explain: In biology, when people talk about the structure of protein molecules, they differentiate between several levels of structure. The primary structure is just a sequence of amino acids, the building blocks that make up the amino acid chain. Secondary structure is for example beta sheets, alpha helices. And then there is tertiary structure, which refers to the 3-D arrangement of these secondary structural elements. And then there's the quaternary structure, which refers to the 3-D arrangement of multiple protein molecules. So here I think we can make the same distinction. The primary structure is the sequence of bases in each strand of a double-helical DNA domain, and we consider double-helical DNA domains as secondary structural elements, which you then connect in a user-defined 3-D topology to give rise to a tertiary structure. Our secondary structural elements, these double-helical DNA domains, can have user-defined length and helicity. A double-helical DNA domain is a right-handed helix that's formed from two DNA strands, and it has certain geometrical properties. And those can be tuned, so the helix can be overwound or underwound. Individual DNA double

helices can also be bent, but the bending is induced as a consequence of constraints that arise in the tertiary structure.

Since each double-helical DNA domain consists of two strands, we have four "outlets," two at each end. These outlets are phosphate backbone linkages, and they can just be transferred into the next secondary structural element. This means you don't need to think so much about the crossovers; we only think about the double-helical DNA domains and how we want to arrange them in 3-D space.

PSR: And the rest follows from that?

HD: That's right. And then you have to figure out the routing, where you route each strand through the 3-D arrangement of these double-helical DNA domains. That's a very simple design paradigm: You only think about double-helical DNA domains and how to connect them in 3-D. And by restricting yourself to B-form DNA and this paradigm, simple considerations can take you very far in terms of structural complexity.

JPS: The thing is, it's difficult for people to imagine why you can build any shape. We have basically stiff pipes, the double-helical DNA, and we can link an arbitrary amount of them in whatever way we want to.

So we can build any kind of layer, like scaffolding on a building, for example, or like a wire mesh. It can have any kind of shape, but it's just straight lines connected at different points. That's our design freedom. We can make any shape, because that's the only restraint. We just have to connect at some point a lot of straight pipes. And they don't even need to be straight. We can bend them, so we have even more choices.

PSR: And once you have built a DNA-based nanostructure, how do you know what you've made?

TM: We have several tools. One is gel analysis. We know if the structure is correctly formed and compact, then it should run faster in a gel than an unstructured object. We just apply a voltage, and because our structures are charged, they run through the gel matrix; depending on the size they run at different speeds, and with that we see if they are well formed or not. And we also see in the gel how many dimers or unfolded structures we have, compared to different kinds of folding products. In the gel we have intercalating dyes, which fluoresce, and with that we see the defined bands.

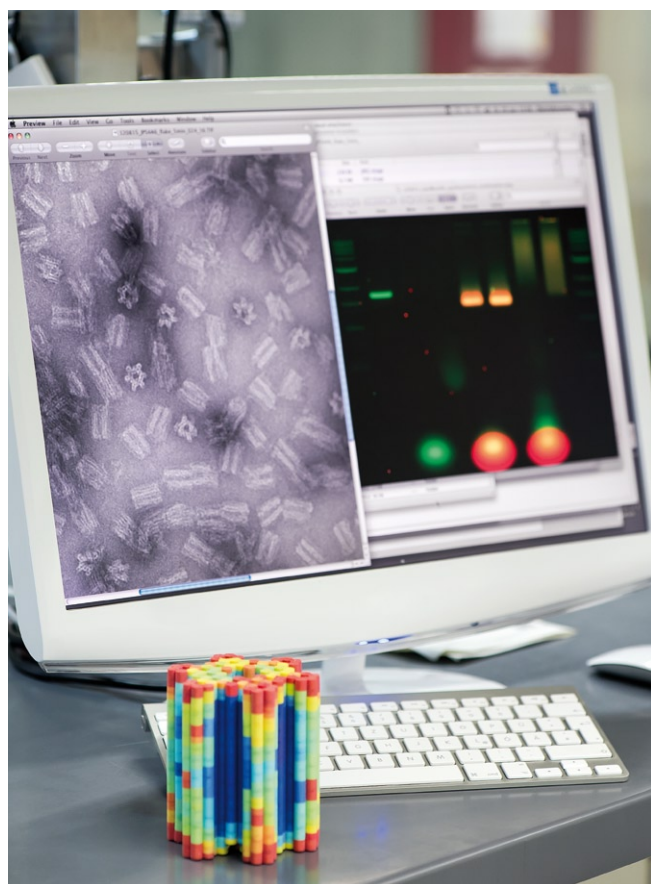

Electron microscopy is the next step. We take the fastest band, the whole folded set, and we look at it, and with that we get a rough idea how the shape is. It's not as exact as you need for real 3-D reconstruction, but the approximate shape is already visible.

TG: That's the only way you know what you did. You have to look at them. And you have electron microscopy or atomic force microscopy methods. To see it with your eyes, this is the only way.

HD: You can still look directly at the folding products that you have in the solution. And then there are indirect methods that report on certain properties of the structure, for example global size, or radius of gyration, stuff like that. And these properties can be interrogated, for example, using chromatographic methods or electrophoretic methods.

PSR: During 2012, your group and collaborators demonstrated DNA-based structures for two potential applications – a "smart lid" for Uli Rant's solid-state nanopore sensors and, with Fritz Simmel's group, a synthetic membrane channel that mimics nature's way of tunneling through cell walls. These seem like big achievements, but are they just the beginning?

HD: Just demonstrating a self-assembled synthetic membrane channel makes it easier to imagine a lot of things: molecular sensors, nano-needles, artificial virus-like devices – for therapeutic purposes of course – even nanomachines powered by the ion flux.

TM: Nanopores, on their own, are pretty amazing, considering the way they allow single-molecule sensing without labeling. But they lack something because they are everywhere chemically the same. With DNA nanotechnology, you really have the possibility to modify a specific site, and this changes the nanopore into something that can be customized, tailored to different purposes.

Tools for determining quality and yield include gel analysis (right) and electron microscopy (left). 3-D prints (below) also make it easier to visualize DNA-based nanostructures.

104 **HD:** The thing is, this DNA-based molecular self-assembly is unique in the sense that it is the only fabrication technology right now that can give you structural complexity and a certain degree of positional control on this length scale of a few to a few tens of nanometers in solution. It can produce chemically registered objects, so that if you want for example to place a fluorescent molecule in a certain position in that structure, you can do it; and if you want to place another reactive group elsewhere, you can do that. And that may seem a mundane feat, not very impressive, but in a way that opens up a whole world of potential applications, because now you can build objects that are commensurate in size to natural macromolecular machines like protein molecules. That means that we can now start building little tools that we can use to manipulate these natural objects. Along these lines, we are pursuing a number of applications where we try to use this molecular self-assembly of DNA to build nanoscale tools and devices that can help us study protein molecules. One example is these nanoplates or “smart lids” for nanopore-based sensing applications. Another example is these synthetic membrane channels, which again may be used as single-molecule sensing devices.

We're also working on grippers that could enable us potentially to hold onto single protein molecules. This could play a role in studying the mechanical properties of the folded state of the protein molecule with the help of optical tweezers, like what Matthias Rief is doing. In this case our structures could increase the resolution of this technique, to measure the fluctuation dynamics of a protein molecule, and there isn't currently any other means to make such stiff grabbers on that scale.



So you could see this as a series of relatively mundane applications where we take advantage of the fact that we can make an object that has a certain length with a certain stiffness, or we can place chemical groups in certain locations. On the other hand, if we only pursue applications that take advantage of the capabilities we have today, then we won't advance the technology.

To some people it seems crazy to think of one day using genomic material, DNA, to build catalytically active objects. I think all you need to do that is sufficiently precise positional control and the ability to create complex objects. So we are trying to push that. Thomas Gerling is working on trying to build designed structures that can be actuated through the addition of chemicals. Jean-Philippe is trying to better understand the self-assembly, when and how these structures put themselves together, which in itself is interesting because basically everything in nature is formed through self-assembly. Maybe we can learn something about protein folding processes by studying the assembly process of these DNA nanostructures. And then Thomas Martin has been working on these channel applications, and another application for structural biology to try to enhance single-particle electron microscopy, basically mixing applications research with efforts to push the boundaries of the field.

PSR: Along those lines, you've also recently published results that suggest you're on the path toward making applications practical, even someday “industrial.” Let's start with the discovery that DNA-based nanostructures can be synthesized rapidly at constant temperatures. What are the implications for the field?

JPS: What people knew was that if you mixed everything and you annealed it for a very long time, you would at the end get the thing that you planned. And it made sense because you know, from base pairing, which is very simple, there's no reason you couldn't plan things in the first place and end up with a special shape. But you didn't know anything about what was going on along the way. It was just like a black box.

So we added a dye that allowed us to visualize the progress of folding actually in real time. We all did this together. And from this we learned a few things that led us to this constant-temperature folding.

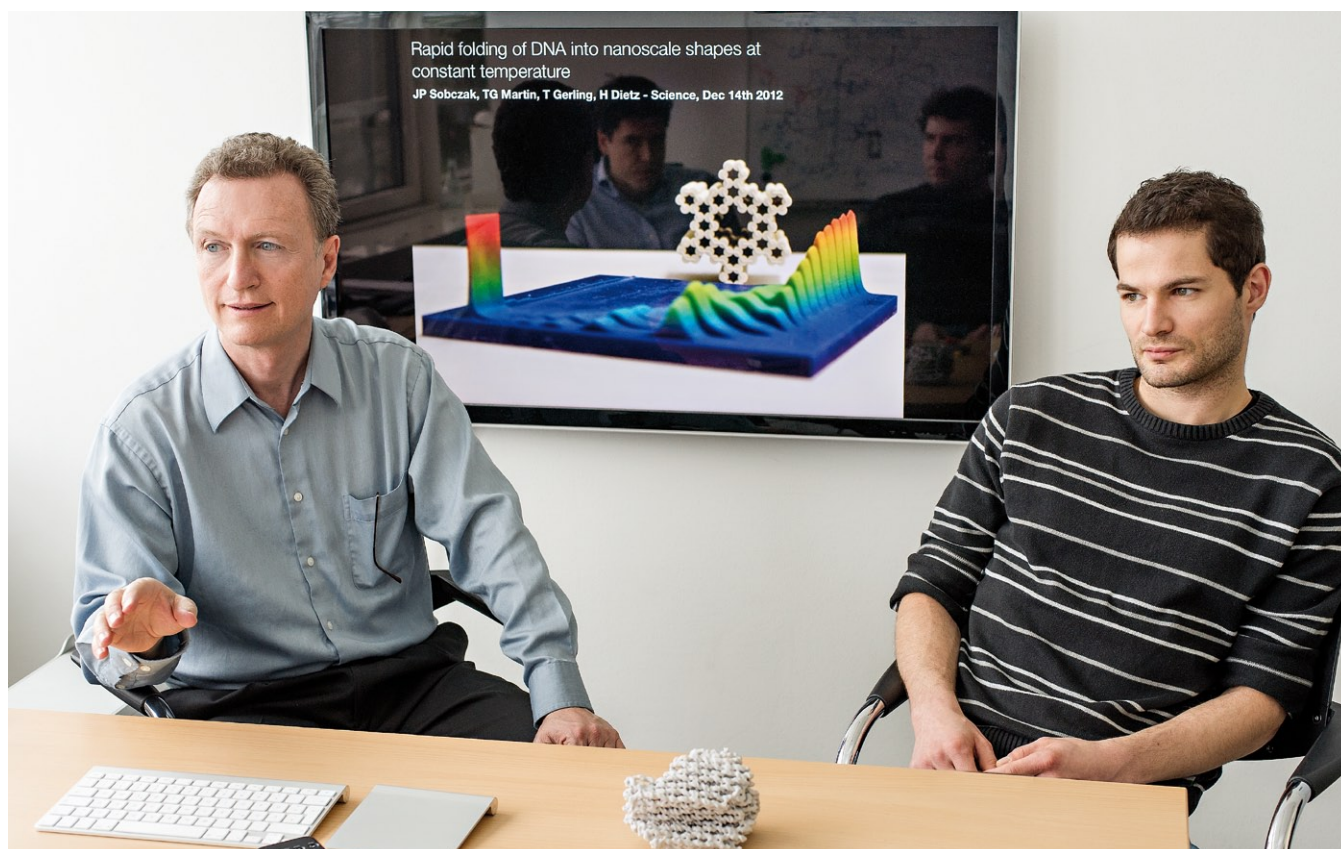

People had different theories about how things would progress, but now we could actually see directly from the data: Here something happens, and in the other parts of our folding process nothing happens. And we could then focus on the temperature range where folding actually takes place.

PSR: This was a surprise in the beginning, wasn't it?

TM: Yes, it was a surprise. Before that we always had these seven-day runs, and we had no reason to expect that we could actually shorten it to a few hours.

HD: Previous protocols involved this chemical and thermal annealing. You had to wait a week and then you got maybe a little bit of your designed product. But these synthesis protocols suffered from low yields. You had a lot of by-products, and you lost a lot of good material on the way through the lengthy exposure to the high temperatures. So while these assembly protocols were good for proof-of-concept studies where we could show what we could make using DNA, you couldn't imagine doing robust manufacturing this way. Then we started looking into how the assembly proceeds and were

surprised to find that the procedure can be shortened, and that it actually can be shortened a lot, and then for some structures we got really satisfactory yields. That makes me believe this really is something we can convert into a robustly working manufacturing method that may have an industrial future, although there are still a couple of challenges that we need to solve.

PSR: As I understand it, to get these high yields in short time periods, you need to find out what's the magic temperature for the particular object you're making. Do you have rules yet, or is it still hit-and-miss?

TG: It's pretty easy to find out with an assay.

JPS: You can measure it, but right now you can't predict it yet, so that's another thing we're going to work on – being able to look at the design and tell what its temperature will be, so you don't have to do the measurement every time. That will be another important step in optimizing procedures, making things even faster. Now we have to run it once at least, to scan it. If you could predict it right away, you wouldn't even have to do that.

106 **TM:** Just from experience, you know whether some structures will fold at high temperatures or they will fold at low temperatures, but it's not so easy to actually understand why. In the broad range of plus or minus five degrees, you can probably estimate it, but to know exactly what you need for this constant-temperature folding, we're not there yet.

HD: I just want to emphasize what Jean-Philippe said. At least now there is a method by which you can rationalize the process of optimizing the assembly conditions. So you can monitor the assembly as a function of temperature and then pick the right temperature range in which the structure should fold. And that's an opportunity we have now, to get the high yields.

JPS: Another good thing is that this might be helpful to people who are trying to build proteins by design. That's a complicated thing because you can't tell right away how something will assemble, there are so many possible directions, and there are no easy rules. But for DNA-based self-assembly, where you have very straightforward interactions, it's reasonable to think you might be able to develop some kind of model.

PSR: Has it already improved your work life that you don't have to wait a week between batches?

TM: It's less excuses.

HD: The throughput has increased dramatically.

TM: Before, you had to work several projects at the same time, because you always had this step where you had to wait for a week.

TG: For most of the experiments, it's important to have a high yield of correctly folded structures, so I'm using this all the time.

PSR: The capability for subnanometer positional control – which you demonstrated for the first time using a specially designed test object and low-temperature electron microscopy – that's a separate issue but with a similar impact, right?

TM: In the past, with normal negative stain electron microscopy, you could always see that these DNA-based

objects had a defined shape, but you never knew how exact it was, or if you had small differences between the structures. And with this cryo-EM study, we could show that you actually can get a very defined shape, and it doesn't vary much from one individual object to the other. We were able to get a very high-resolution cryo-EM 3-D structure out of it, and we could actually know where a specific base is in three-dimensional space.

PSR: Where would you place these results on the continuum of progress in the field?

HD: The broader field of molecular self-assembly has been around for three decades. Thirty years ago Ned Seeman, a crystallographer, started this whole field. He always cracks the same joke when he talks at conferences: no crystals, no crystallography, no crystallographer. So he was thinking about how to facilitate the preparation of crystals. He had the idea of using DNA as a template for 3-D crystals, which would serve as a host for guest proteins and thus would help in the structural analysis of those proteins. That's how this started back in the 1980s, stitching together DNA molecules to form bigger structures. In the 1990s he first demonstrated, for example, a little cube made of double-helical DNA domains, and then the field was slowly growing toward more complex structures, which were never really validated in detail.

Then in 2006 there was a breakthrough, a new approach to design that came to be known as DNA origami. Paul Rothemund from Caltech pioneered this. He wrote one beautiful single-author cover story in *Nature*, with a 95-page supplement, and he showed the tremendous potential of this new assembly method. He was the first who really made fairly complex objects. But still, the structural validation of these objects was rather coarse.

But all the people in this field were operating on the assumption that DNA-based self-assembly should give you subnanometer-precise positional control. And skeptics were criticizing the field for the lack of high-resolution structures, arguing that this indicated an inability to produce something that is structurally well ordered. So counter to the assumptions, the skeptics argued that what people were making was just pudding, or heterogeneous, or floppy, and therefore not useful for anything.

From this perspective, our high-resolution structure is very useful because it validates this assumption: that we can make structurally defined objects that have a high degree of order, comparable to what you find in protein molecules. This in turn suggests that you really may use these structures as high-resolution scaffolds to position reactive groups in space with subnanometer accuracy, and thus obtain more complex functionalities. And I think everybody in the future will be happy that we now have this structure. One should say though that the quality of synthesis, which is what enabled us to make such a large and complex test object in the first place, definitely owed a lot to the experience we had gained over the last three years or so.

PSR: With this kind of validation, is this the best time yet to be doing research in DNA nanotechnology?

TG: We are all physicists, and I think this area of biophysics is one of the only fields where a physicist can do something really new. For me, that's the most important thing.

TM: We all started before this breakthrough, where we could know for sure that we can build things with high accuracy. But the really interesting thing is that you never know what to expect. You may get some results

that you never thought of before, and that's possible largely because it's so new.

JPS: When I started, I was looking around to see which lab I wanted to work in. Then I came to Hendrik, and he said: nanomachines. I thought of nanomachines as something you would see in a science fiction movie. But OK, you're already doing it? I guess I'm going to stay here. Sounds good.

HD: One of the many interesting aspects of this field is that we're not at a point where we have 99 percent of everything figured out, and the next goal is to figure out 99.5 percent. Here we are at one percent or so of the actual potential of the field, and so everything we're doing is a huge step. Of course it's hard work, and there's a lot of suffering involved, because there's so little known and it's easy to make lots of little mistakes. You don't always know what's going on. So you try to establish a machine that has whatever conformation and dynamics you want, and then you find it hard to prove that it works that way, because you have to first figure out the assays to analyze it properly. And then you encounter artifacts that have to do with the measuring techniques and things like that, so it's still a hard business. But the risk-benefit ratio is right: high-risk, high-reward.



108 **PSR:** What are some of the most interesting problems facing you now?

TG: For me the next step is definitely to build dynamic DNA structures. So far all of these close-packed, 3-D DNA nanostructures are static in nature. Therefore the next step would be to build dynamic devices out of DNA.

PSR: So this is getting to your flagellum machine.

TG: Exactly. The first step would be to build a switch-like structure in which you can change the conformation upon some stimulus, chemical or temperature or pH or something else external, and thereby change its structure.

PSR: Like an actuator or a relay.

TG: Yes. This would be the very first step if you want to build something like the flagellum motor or ATP synthase or the ribosome or all these other fantastic nanomachines.

HD: With the natural macromolecular machines, there are certain analogies – to macroscopic motors, for example. They have movable parts, and these movable parts can be shifted from different structural arrangements through stimuli, mostly chemical. In the macroscopic world, if there's a motor with pistons and cylinders, you need a crank to run it through the different configurations. On the nanoscale, the different

conformations are attained thermally, through fluctuations, but they can be biased depending on the binding or unbinding of small molecules. And that's a quality we still need to implement into these nanostructures so they can be made active.

JPS: We have this step, from design to shape, that works pretty well I think. And now – the actuator is one example – we're facing the step from shape to function. I think everybody is working on this in some way right now. And that's probably where the most interesting things will happen.

HD: Another challenge will be scaling up the fabrication. There's typically 500 milligrams of salicylic acid in an aspirin tablet. Suppose you had a DNA nanodevice that could act as a drug delivery vehicle, and you wanted to make a tablet with 500 milligrams of that substance. With current material costs, that would amount to around 150,000 euros for one tablet, and that's a conservative estimate. And using current equipment and procedures, it would take you about two months. I don't think reducing the cost of synthesis and scaling up the throughput would be particularly difficult. But it remains to be done, and it's another aspect holding us back from broader applicability in areas such as health and chemistry.

PSR: Thinking ahead a few years, or even a few decades, what are your hopes and expectations for progress in biomolecular nanotechnology?



TG: What I would like to see is a synthetic DNA machine that has the functionality of biomolecules, like these machines we have talked about.

TM: I expect that there will be medical applications for DNA nanotechnology. It could also play an important role through fast prototyping. That is, when we understand the whole process better, it should be a simple matter to place chemical groups precisely where you want them.

JPS: You could say that people are using nanomachines now to produce therapeutic substances, but we can't build them ourselves yet, you have to use bacteria. But bacteria are not made for that. It's not optimal. Once you can build your own nanomachine, then you might be able to catalyze reactions and produce whatever you want with higher efficiency because it's designed only for that.

TM: You might be faster in reacting for specific things. Medicine always takes a lot of time to make something new, but with this technology you might have a very fast way to design something very specific.

HD: Well, you know, I have a wild imagination, so I can think of all kinds of crazy stuff. Imagine you could build anything bottom-up, with atomically precise control. Everything. So you could build some sort of synthetic wood for example. In a way, even wood is atomically precise. It is cells made out of certain components



arranged in 3-D structure, and it's all self-assembly. Imagine you understood the whole thing. So you could build molecular structures that interact with other molecular structures, and you could program their assembly on a "tape," as in nature, like a genome. And they form, they interact with each other, they build something like an analogon of a cell, but it could be arranged a different way. It grows, it combusts raw materials, it makes duplicates of itself, and you make a tree for example that grows into the shape of a house. It builds itself, basically, based on energy input from light and raw materials it finds in the soil.

Maybe more realistic – I think it's certainly conceivable that in 30 years we can build something like artificial viruses. The word has a negative connotation because it's usually associated with disease. But imagine you could build a synthetic particle that has the functionality of a virus and is capable, for example, of killing bacteria that cause disease in your body. You build some sort of nanodevice that selectively seeks out cancer cells and gets rid of them. Something that is useful but as sophisticated as we find in nature. Or think about vats filled with membranes in which you have little rotating nanomachines powered by ion current, and the rotary movement is used to control mechanically induced chemical reactions. So then you have these nanomachines that take in raw material, like smaller molecules, and stitch them together into long polymers: It could revolutionize chemistry.

And maybe thirty years from today we'll have a number of applications where this plays a role, but not in a very noticeable way – where it's invisible because it has become common technology.

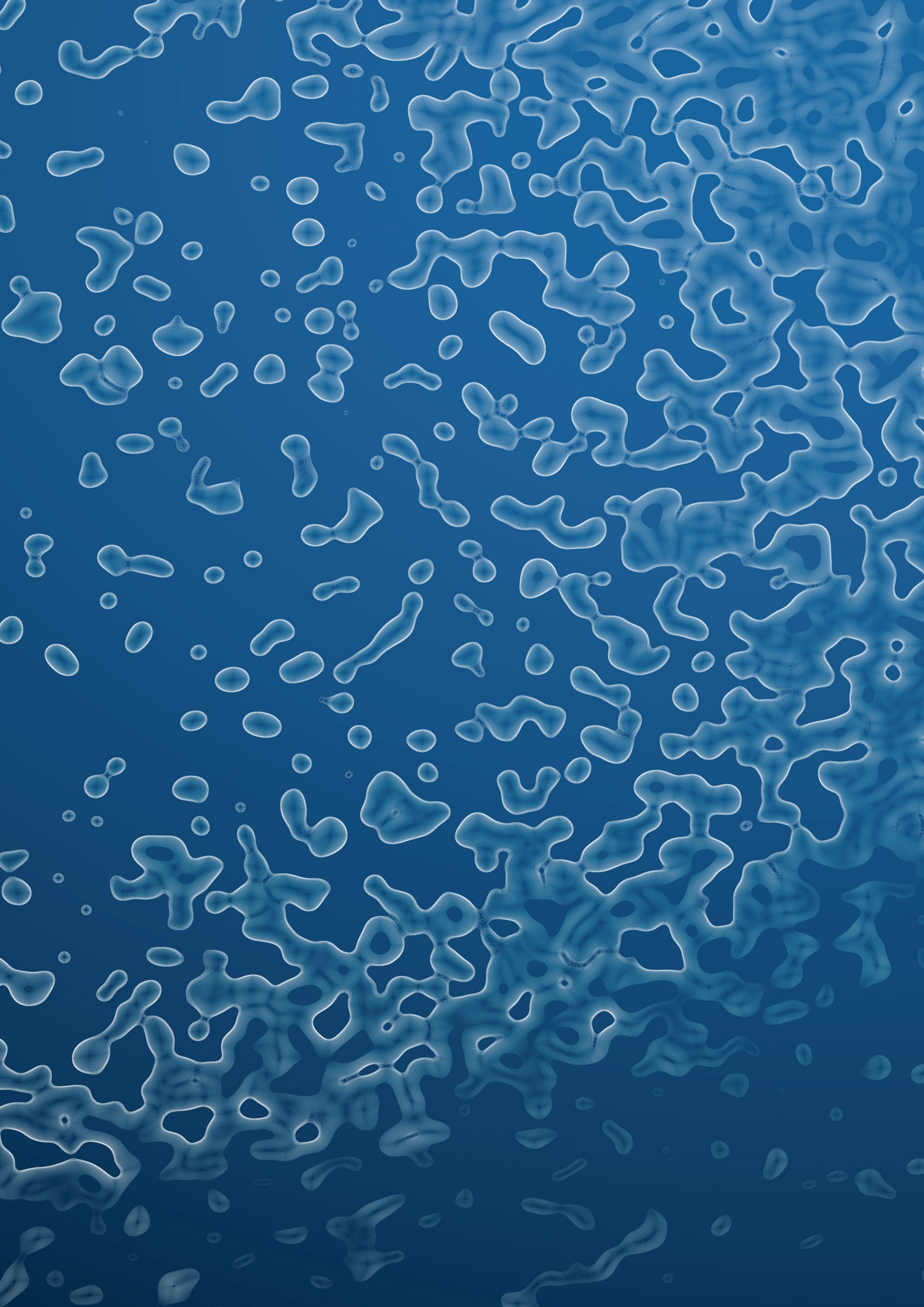



Five Years TUM-IAS: A View

Five years TUM-IAS: A View

By *Patrick Dewilde*, Director

With the continuation of the support for the second round of the German Excellence Initiative awarded in 2012, TUM-IAS is ready for its next five years of effective existence. In this contribution, I would like to look back at its first five years and make a connection to the future.

TUM-IAS is like a symphony: many attuned voices shaping the theme “innovation in research.” Here is an overview in four movements and a bit of how it was first composed and then developed its theme. The symphony is, of course, incomplete, just the first notes of the next fifth movement can be heard.

Prelude

The Institute was conceived by its founding fathers Profs. Wolfgang A. Herrmann (President of TUM), Ernst Rank (at that time Vice-President) and Dr. Günther Schmidt-Gess (at that time Scientific Advisor to the President) who wrote down its blueprint in the “institutional strategy” for TUM as part of the first phase of the Excellence Initiative. When the plan was agreed on, the founding fathers quickly sought assistance from a number of top scientists inside and outside TUM, not only to give it a head start, but also to receive advice on good practices, in particular from experience with Institutes for Advanced Study elsewhere. A new building was foreseen to turn the Institute into a focus point of TUM and it was necessary to design and shape it properly. The early staff of the Institute went on visits to the Princeton Institute for Advanced Study and the Peter Wall Institute for Advanced Studies in Vancouver, and got invaluable advice. The two directors of these institutes agreed to become members of the new to be formed Board of Trustees. Some of TUM’s top scientists and some from abroad became the very first Fellows and trail-blazed the Fellowship program. Others joined the Board of Trustees. Thanks to this very pro-active early strategy, the new baby came to life almost fully equipped, with a complete blueprint.

First movement: allegro assai

In 2007, things started to develop, opening up like a flower in spring. The BMW Group agreed to finance the new building in the center of the Garching campus. The search for a full time director was on, and although it took a while to get all the approvals, I was the lucky recipient. I had already quite some experience with TUM as I had been a Humboldt Prize winner with Prof. Klaus Diepold. Dr. Markus Zanner, with whom I immediately had very productive contacts, became the

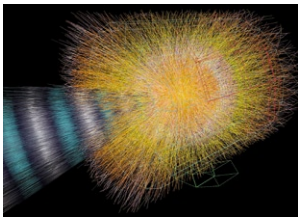

Managing Director. Temporary offices were set up in a building on Nymphenburger Straße, very nice if not a bit cramped headquarters. Born under good augurs, well conditioned and settled, the young sapling could start its growth.

However, an Institute stays or falls with the quality of its Fellows, and from the very beginning TUM-IAS had a wonderful cast to start with: in the Carl von Linde Senior category: Andrzej Buras, Arthur Konnerth, Reiner Rummel; Carl von Linde Junior: Adrian Jäggi; Hans Fischer Senior: Gerhard Beutler, Walter Kucharczyk, Bert Sakmann; Hans Fischer Tenure Track: Thomas Misgeld. As can be surmised from the list, some fields were very heavily represented in the early days: neurophysiology and geodesics, but a beginning was also made with particle physics and medical instrumentation. These early pioneers not only produced some of the strongest scientific results (*in vivo* neuron measurements and the GOCE satellite gravity measurements), they also gave the Institute an early backbone in sturdy, multidisciplinary science and a reputation of excellence.

Second movement: allegro con brio

2008 and beginning 2009 then marked the time for serious “strategy” development in the Institute. The Main Goal: contributing to the innovation of the research environment at TUM in light of the development of modern science and technology; the Means: establishing deep international scientific exchange through long-term (three-year) international Fellowships (Hans Fischer Senior Fellows), attracting the most promising scientists to the TUM community as Carl von Linde Junior Fellows and helping to consolidate the main multidisciplinary and innovative research clusters at TUM by facilitating the influx of talent.

The full development of the program brought in not only new Fellows, but also new fields, let me mention in particular chemistry, stochastic systems, nanophysics, biophysics and robotics. The decision was made early on not to go for an isolated “ivory tower of excellence” nor for fleeting occasional contacts and ad hoc events, but to anchor Fellows and their activities very strongly in the TUM faculties. To use a biblical term: they should be the salt of the TUM scientific environment. Research units at TUM who proposed and acquired Fellows, and provided a working environment for them became our Focus Groups and their Hosts became members of the Institute at the same token. With the fast growth of the Institute it became urgent to increase both its scientific, managerial and secretarial staff, which succeeded beautifully. The smooth interaction of (in particular international) Fellows and TUM-IAS staff became an unsurpassed hallmark – TUM-IAS soon acquired the reputation of a most efficient and “user-friendly” (our users being our Fellows and Focus Groups) organization.

Third movement: presto

The second half of 2009 and then the whole year 2010 were instrumental in moving the Institute into full-fledged operations, under the guidance of our Advisory Council, which consists of a selection of our main science leaders, both from the Institute and from TUM. We started with a major expansion of our Fellowship program in two directions: Carl von Linde Junior and Rudolf Diesel Industry Fellows. Although the average age of the Fellows so far was very much around a relatively young 50, we wanted to make the Institute an attractive place for the most promising junior scientists as well, in balance between inside and outside. This would also provide a change towards more gender diversity, as the senior collection of engineers is heavily tilted towards males. Ten new Carl von Linde Junior Fellows joined.

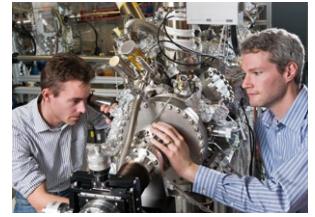

Another direction we wanted to develop was to attract top researchers from industry who would contribute to the innovation of our research as Fellows. What would motivate industry researchers to set up research in a university environment, and how should that be accommodated? The insight grew that our Industry Fellows might appreciate a similar approach as with our international Fellows, namely that we offer them the possibility to develop a very personally conceived research project in close collaboration with a research unit at TUM, using the freedom and openness of the university to “explore the unexplored” or even the inexorable. Undisputed trailblazer was Prof. Khaled Karrai, co-creator of attocube systems AG, a Munich start-up company that grew out of the Munich efforts in nanotechnology and is now a worldwide leader in equipment for nanoscale measurements. Prof. Karrai was soon joined by Fellows from Siemens, CASSIDIAN, Nippon Shokubai Ltd. and AMEC Geomatrix Inc.

In this period, we also made some headway with our Tenure Track Fellowship program. In recognition for his trailblazing work on DNA origami, Prof. Hendrik Dietz became our second Hans Fischer Tenure Track Fellow, consolidating our Biophysics Focus Group. Furthermore, each of the new Carl von Linde Senior Fellows started a major effort of creating a new field at TUM: Prof. Axel Haase brought MRI and PET-MRI to IMETUM (Institute of Medical Engineering), Prof. Gerhard Abstreiter created our new multidisciplinary nano-science facility ZNN (Center for Nanotechnology and Nanomaterials) and Prof. Ulrich Stimming developed a much needed energy-oriented consortium.

The large if not enormous influx of 14 Hans Fischer Senior Fellows generated a wealth of new activity at TUM. Let me single out just one example: Prof. Dirk Busch was a recently appointed (and young) professor in immunology at the Faculty of Medicine, wondering how he could push his ideas on moving cell-based therapy from research to clinical practice. He had extensive experience with instrumentation for cell processing and a great admiration for Prof. Stanley Riddell of the University of Washington in Seattle, who had pioneered several of the basic methods. Busch came to visit me with the question how the Institute could be instrumental in helping him realizing his dreams. I suggested the use of our Fellowship program, and he ventured to contact Prof. Riddell and get him to join his efforts as a Hans Fischer Senior Fellow. At the same time he also proposed Dr. Christian Stemberger as Carl von Linde Junior Fellow and attracted doctoral candidates (also supported by the Institute) to consolidate the effort. A new and extremely active Focus Group was born; the new instrumentation has been successfully developed and has now reached the state where it can be used clinically – potentially a major contribution to future medicine.



Fourth movement: andante

After the impetuous growth of the Institute in the academic year 2009–10, it was time for consolidation. This had to happen in different directions. The construction of our new building, that was donated by the BMW Group at the tune of ten Mio. Euro, in the center of the Garching campus, was making quick headway. In the good tradition of the BMW Group, everything was realized precisely on time, not a single day delay on anything, even though an unforeseen underpass under the building had to be constructed as well, catering for potential extension of the U6 metro line! The opening ceremony took place October 21, 2010, followed by an inaugural symposium on “Energy and Electromobility” on the 22nd. In parallel, another building downtown Schwabing became ready to accommodate some of our Fellows: a very attractively located elegant city house donated by the Fritz und Lotte Schmidler-Stiftung and renovated by TUM. The building offers five well-furnished and beautiful apartments, making TUM even more attractive to our visiting Fellows.

From a programmatic point of view, the flight upwards started in 2010 was continued into 2011 with the nomination of one Carl von Linde Senior, two Carl von Linde Junior, and five Hans Fischer Senior Fellows. So doing, the Institute had reached a good measure of completion. A few potential issues that played in its original set up were successfully resolved: a good balance between experienced and junior scientists for one, the creation of a strong industry oriented program via the Rudolf Diesel Industry Fellows for another.

As things go with young institutions, some changes in the managing staff had to occur. Dr. Markus Zanner left us to become Chancellor of the University of

Bayreuth. He was replaced by Dr. Ana Santos Kühn, a former doctoral candidate of Prof. Herrmann and his former chief of staff, who very quickly integrated herself in the staff and contributed substantially to the Institutes’ future outlook by structuring its finances to allow for long-term decision making.

Our new building became an immediate success. Its architectural beauty and manifold of facilities (auditorium, faculty club, atrium and other breakout rooms) immediately attracted lots of events, mostly from research units within TUM, but also from outside. The Institute’s Focus Groups became very active in organizing “exploratory workshops” designed as think tanks on new topics for research. They would consist of a group of 10–20 internationally reputed researchers meeting for a few days to intensely interact on not yet well defined but promising new research or even societal issues. The informal setting and comfortable accommodation enhances openness of discussion and mutual understanding. This kind of interaction was then further supported by a number of measures intended to consolidate the international community of TUM around the Institute. A program for “Visiting Fellows” was created that would support short-term visits from top scientists from abroad. In parallel, the TUM allowed faculties to appoint “TUM Distinguished Affiliated Professors” who automatically became members of the Institute, a favor that was also granted to ERC grantees (European Research Council), Gottfried Wilhelm Leibniz Prizewinners, and Research Awardees and Professors of the Alexander von Humboldt Foundation. This created a logical and large international community in which our Fellows could feel at home and an almost singular point of condensation for multidisciplinary interaction.



As far as research areas go, there was, of course, a new broadening of the program thanks to all the new nominations. Let me make a broad painting of the situation: first of all, nanoscience and biophysics developed further with a lot of new ideas and Fellows, both theoretical and experimental. Another, for the Institute new field that came up strongly was advanced computing, in various directions and by very distinct players. One direction was towards so-called multi-physics, both numerically and theoretically, with keen interest on handling a large number of dimensions as well. Another direction was towards advanced numerical modeling, mostly in the biomedical sphere, in particular modeling the human heart and human bones. Still another computing direction had to do with dynamical system modeling and control, from humanoid robots to automatic driving and even combat aircraft. Needless to say: lots of room for interaction between Fellows of very different disciplines, competition, even criticism. A third new area of endeavor was in the general sphere of ecology, with groups from the life sciences faculty joining the Institute. Although most of this may look pretty “scientific,” also the engineering and medical sides came in forcefully, with topics like nanoimprint and nanotransfer, fiber optic communications, metropolis non-formal architecture, and engineering risk analysis.

Much of 2011 was spent by the TUM-IAS management team preparing for the evaluation of the first round of the Excellence Initiative, conceiving our future strategy and deciding on how to defend of our ideas before the evaluation commission, which would be visiting on November 17, this, of course, in close collaboration with all our partners within TUM and under the expert leadership of our President. Although it was not quite clear on what criteria our performance in the period 2006–2011 would be evaluated, we decided to take no chances and, with the help of all our Fellows and Focus Groups, we wrote a “White Paper” on all quality criteria we could imagine. This, together with the impressive poster and laboratory presentations of our Focus Groups convinced the visiting members of the evaluation commission of the plus value the Institute contributed to the development of TUM as a leading scientific and educational institution worldwide. We got enthusiastic feedback on our achievements, matched, by the way, by the very impressive conduct of the evaluation overall and the immense participation of the whole university community. This was a truly moving and convincing performance! It took another seven months to obtain the formal and successful result, but all is well that ends well!

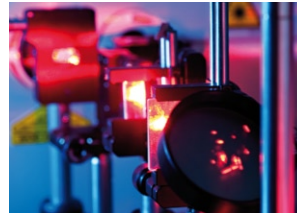

Beginning of the fifth movement: setting a new tune

Moving into 2012 also meant terminating the first round of the Excellence Initiative in an elegant way. Although there would be a non-negligible spill over of commitments, in principle the new round would also mean a new beginning. We shall, of course, continue our very successful and proven Hans Fischer and Rudolf Diesel Industry Fellowship programs more or less as before. But we do propose a major change in the Carl von Linde and Hans Fischer Tenure Track programs, in line with the new TUM Tenure Track program. Our new “Rudolf Mößbauer Fellowships“ aim at attracting young professors internationally with a specific TUM-IAS flavor, namely an emphasis on the creation of new fields of research at TUM, based on a promising original vision. The previous Hans Fischer Tenure Track Fellowship program was a first attempt in this direction, but it was handicapped by a lack of institutional support for tenure track positions. However, an important issue in realizing the program is its financing. The European Union came to the rescue with its Marie Curie mobility program CO-FUND, which will provide 40% of the funding under the condition that the awardees are carefully selected top class young researchers from abroad. Even so, the tenure track program remains very expensive and requires a very substantial further allocation of funds. That then meant a restructuring of our Fellowship programs for internal scientists, with a greater share going to the new Tenure Track Fellows, and hence a lesser to the Carl von Linde category. Rudolf Mößbauer was a TUM Professor, Nobel Prize Laureate and great physicist, who unfortunately deceased in 2012. The program has become operational as of November 2012.

In 2012, TUM-IAS awarded two Hans Fischer Senior, two Hans Fischer Junior and three Rudolf Diesel Industry Fellows. For the first time we used independent (blind) juries to rank proposals on the basis of CV, statement of purpose and peer reviewers' comments. Jury members were all top personalities in the TUM environment, who know TUM well, have performed extensive services and can be trusted to make an independent and adequate grading of the nominations. The juries would grade on two characteristics: scientific excellence of the candidates and innovativeness of their statement of purpose. The grades of the members of each jury have to correlate significantly to be valid. This actually happened as expected and led to a result that was submitted to the Advisory Council, who has the right to make further decisions on cases where the jury ranking is not clear cut, and advise on the allocation of funds.

The end of 2012 marked a new change in the management team: Dr. Ana Santos Kühn became the director of the TUM International Office and TUM Global, while Stefanie Hofmann, since 2008 already a much appreciated TUM-IAS Program Manager and head of staff, became our new Managing Director.

Thanks to the various awards the Institute has obtained in 2012, it can now move on into the planned new phase of development in the next five years. How this will go is a part of the symphony that still has to be written, but I can certainly conclude that the initial concepts on which the Institute was based, in particular a sturdy and long term Fellowship program aiming at research innovation have now convincingly proven their value, showing that our Founding Fathers had the right vision from the start.



Institute Activities



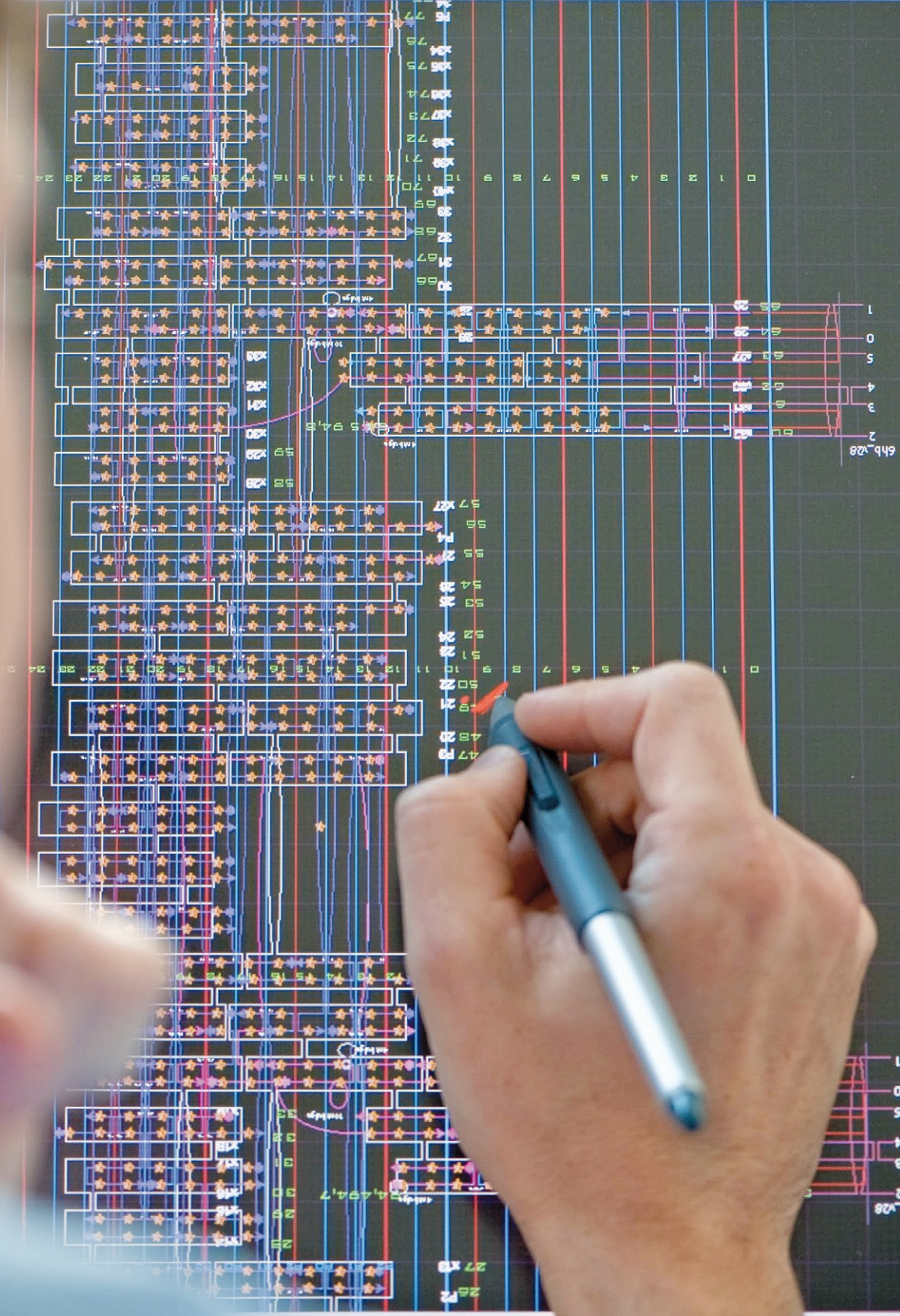

The TUM-IAS Fellows' Lunches have proved to be successful events where TUM-IAS members are given the chance to meet and talk in a relaxed, familiar atmosphere once a month throughout the academic year. For each Fellows' Lunch, speakers are invited to give presentations on a chosen topic of general interest with the possibility of discussion among the participants afterwards.

These lunches not only aim at strengthening the network within the Institute's community but first and foremost to advocate a multidisciplinary approach and exchange among the TUM-IAS Fellows.

At the Fellows' Lunch in February Prof. Horst Kessler introduced the TUM-IAS community to the clever chemistry of spider silk production, and how this process can actually be engineered. In March, Prof. Dongheui Lee followed with presenting her research project in the Focus Group Cognitive Technology for the first time. In the next month, young entrepreneur Dr. Ulrich Rant enlightened the community on "How to squeeze a billion dollars through a tiny hole – nanopore sensors" by showing recent results on his nano-sensor research and realizations. In July, TUM-IAS Host Prof. Steffen Glaser presented his ideas on "Optimal control of spin dynamics in magnetic resonance spectroscopy, imaging and quantum computing" and Prof. Steven D. Glaser, former TÜV Süd Stiftung Visiting Professor and TUM Distinguished Affiliated Professor, introduced his research about laboratory earthquakes. At the Fellows' Lunch in October, Dr. Jennifer Girrbach, member of the Focus Group Fundamental Physics, gave an update on the Higgs search at Large Hadron Collider (LHC) followed by TÜV Süd Stiftung Visiting Professor Dr. Josef Oehmen on "Challenges and Best Practices in Managing Large-Scale Engineering Programs".

The topic of the Fellows' Lunch in November was "New Programs in Energy Research at TUM" with Prof. Friedrich Simmel giving an overview on the measures of the second funding phase of NIM (Nanosystems Initiative Munich) and TUM-IAS Host Prof. Hubert Gasteiger introducing current collaborative battery projects at TUM (such as ExZellTUM, LiSSi and VARTA). The year was concluded by a talk on "Intraoperative Image Guided Radiation Therapy" by Dr. Michael Friebe.

- January 9 Talk **Carbon Nanotubes and Graphene: Preparation, Assembly and Application**
Speaker: [Prof. Zongbin Zhao](#) (Dalian University of Technology) | TUM-IAS Visiting Fellow
- January 19 Lecture Series “Science and Society – Meet with Excellence”
Die Rolle der Information in einer vernetzten Welt – Informatik als Treiber der Informationsgesellschaft
Organizers: Carl von Linde-Akademie, TUM-IAS
Speaker: [Prof. Manfred Broy](#) (Software and Systems Engineering, TUM)
- February 6 Talk **Quantum Hall Effect and the New Kilogram**
Award Ceremony for Prof. Klaus-Olaf von Klitzing to “TUM Distinguished Affiliated Professor”
Speaker: [Prof. Klaus-Olaf von Klitzing](#) (Max Planck Institute for Solid State Research)
- March 28–30 Workshop **Resilience as Requirement for Sustainable Development – A Contribution to Tackle the Earth Crises**
Organizers: iesp, TUM-IAS

In September 2008, the participants of the workshop on “Earth System Engineering: The Art of Dealing Wisely with the Planet Earth” identified four major, closely intertwined global threats resulting from

- global warming & climate change (1),
- deficiency of energy, water and food (2),
- loss of ecosystem function (3), and
- progress of instabilities of societies and economies (4).

It was concluded that mitigation of such threats requires concerted action of science and society. However, the question remained open which kind of action might be most effective in getting safeguarded the life enabling condition on Earth and prosperity of humanity alike.

In the framework of a follow-up workshop they wanted to explore whether thermodynamic considerations, the theory of non-linear dynamic systems and the resulting philosophy of resilience and sustainability might provide a sound platform for making decision on actions to mitigate the above mentioned complex of global threats. The participants of the workshop were called upon answering the question how to preserve the capacity of the Earth System to withstand anthropogenic impacts. How to purposely preserve or even strengthen the Earth System’s resilience? The goal was to gain a better understanding of the resilience and the limitations of the earth systems and to develop recommendations for actions and necessary research.

April 25–27

TUM-IAS General Assembly

Schloss Hohenkammer

123



As in the year before, the TUM-IAS community gathered at Schloss Hohenkammer, just a 30 minutes drive away from the city, but in its tranquility already very far away from busy Munich. For three days, our members had the chance to come together, learn about our Focus Groups' progress and results, meet new Fellows, discuss and relax in a unique castle atmosphere.

Not only our Fellows, but also a number of TUM Distinguished Affiliated Professors, ERC grantees, and Visiting Fellows could be gained as speakers. The talks covered research fields from Medicine and Biomedical Engineering, Nanoscience, Chemistry and Physics to Risk Analysis and Computing, Design and Control, with topics such as "Oral Availability - the Holy Grail in Medicinal Chemistry of Peptides," "Haptic Interaction in Human-Human and Human-Robot Dyads" and "Molecules that Break Nature's Least Reactive Bonds." Lively discussions continued beyond the program, for which the castle courtyard and the castle's comfortable furnishings provided the ideal setting.

As has become a tradition, the members of our international Board of Trustees came together at the assembly's last day to discuss the Institute's future strategy.

May 2–4 **Workshop *An Integrated Approach to Water Research and Technology Development***

Organizers: IGSSE, TUM-IAS

Speaker: [Prof. Ingrid Kögel-Knabner](#) | Carl von Linde Senior Fellow

[Dr. Chin Man W. Mok](#) | Rudolf Diesel Industry Fellow

Water Science and Water Technology cover a wide area of disciplines ranging from the examination of the fundamental properties of water and its dissolved and particulate constituents to the development, optimization and operation of hydro-power, water and wastewater treatment plants. During the past centuries, major efforts have been made to learn about physical, chemical and microbiological processes that take place in aquatic systems, and use the acquired knowledge to solve specific problems from the micro-scale to the macro-scale. Such specialized investigations will continue to be of importance. The impacts caused by climate change, the excessive growth of human population, urbanization and lifestyle changes, however, make it indispensable to supplement this approach with an overarching integration of scientific disciplines, including those which in the past were not directly engaged in the water sector. Such a cross-cutting approach is necessary to safeguard human civilization and protect structure and function of aquatic and terrestrial ecosystems alike.

It is anticipated that cross-disciplinary integration will lead to urgently needed technological innovation as well as to innovative water management practices and measures which facilitate decision-making at the level of local and national water authorities und supra-national governmental institutions.

The workshop was aimed at identifying future challenges of water research at large, water technology development and water management tools. It was assumed that innovative concepts and methods are likely to develop at the interface between disciplines. Thus, top-level scientists and early career scholars representing various domains of water science and technology were brought together with the intention to stimulate insight, to provoke novel ideas, to exchange information about innovative methodology and to build-up strong interdisciplinary and international cooperation.

May 6–8 **1st Munich Workshop on Bidirectional Communication and Directed Information**

Organizer: [Prof. Gerhard Kramer](#) (Communications Engineering, TUM)

May 8 Chinese-German Workshop **Sustainable Development of Megacities: A Mega-Challenge for China and the World**

Organizers: iesp, TUM-IAS

May 9 Lecture Series **Filtering, Prediction and Smoothing for Stochastic Dynamical Systems**

Organizers: Mathematics Department, TUM-IAS

Speaker: [Prof. Sanjoy Mitter](#) (Massachusetts Institute of Technology) | TUM-IAS Visiting Fellow

May 10 Inaugural Lecture **Carbon Sequestration in Soils**

Speaker: [Prof. Ingrid Kögel-Knabner](#) | Carl von Linde Senior Fellow

Soil sustains life. It is vital for the production of food and fiber which helps to feed an ever-growing population and also for the provision of the Earth's primary

renewable resources. Soil is built of a dynamic and hierarchically organized system of various organic and inorganic constituents and organisms, the spatial structure of which defines a large, complex and heterogeneous biogeochemical interface.

A significantly advanced understanding of the structure, dynamics and functioning of the soil architecture holds the promise to explain organic matter stabilizations within a general mechanistic framework and thus will launch the integration of this information into field-scale concepts and models of CO₂ sequestration in soils.

125

- May 15–16 Summer School **Linear Systems Theory & Subspace Identification**
Organizers: TUM-IAS Focus Group Advanced Stability Analysis,
Chair for Thermodynamics
Instructor: [Prof. Arun Tangirala](#) (Indian Institute of Technology, Madras) | TUM-IAS
Visiting Fellow
- May 16 **John von Neumann Colloquium**
Organizers: [Prof. Claudia Klüppelberg](#) | Carl von Linde Senior Fellow
[Prof. Barbara Wohlmuth](#) (Numerical Mathematics, TUM)
Speakers: [Prof. Sanjoy Mitter](#) (MIT) | TUM-IAS Visiting Fellow
“Statistical Inference and Statistical Mechanics for Diffusion Processes”
[Prof. Reinhold Schneider](#) (MIT) | John-von-Neumann Visiting Professor
“Electronic Structure calculation - a backbone of computational material science”
- May 21–23 International Workshop **Advanced Robotics and its Social Impacts**
Organizer: [Dr. Kolja Kühnlenz](#) | Carl von Linde Junior Fellow
- May 24 Lecture Series “Science and Society – Meet with Excellence”
Die Psychologie des Risikos: Wie Menschen mit Ungewissheit umgehen
Organizers: Carl von Linde-Akademie, TUM-IAS
Speaker: [Prof. Ortwin Renn](#) (University of Stuttgart) | TUM Distinguished
Affiliated Professor
- May 25 Lecture **Data-Driven Causality Analysis**
Speaker: [Prof. Arun Tangirala](#) (IIT Madras) | TUM-IAS Visiting Fellow
- June 1 Lecture **Nonlinear Self-Excited Thermoacoustic Oscillations:
Intermittency and Flame Blowout**
Speaker: [Prof. Raman I. Sujith](#) | Hans Fischer Senior Fellow
- June 21 Talk **IceCube: Particle Astrophysics with High Energy Neutrinos**
Award Ceremony for Prof. Francis Halzen to “TUM Distinguished Affiliated
Professor”
Speaker: [Prof. Francis Halzen](#) (University of Wisconsin-Madison)
- June 15 Talk **Bio-Electrochemical Processes – A New Platform Technology with
Broad Applications**
Speaker: [Prof. Jurg Keller](#) (The University of Queensland, Australia) | TUM-IAS
Visiting Fellow
- June 25–29 **The 11th International Symposium on Parallel and Distributed Computing -
ISPDC 2012 in conjunction with MAC Summer Workshop 2012**
Organizers: TUM-IAS Focus Group High Performance Computing, LRZ

- July 2–6 Workshop **Sparse Grids and Applications**
Organizer: [Prof. Markus Hegland](#) | Hans Fischer Senior Fellow
- July 4 Talk **Polycarboxylate Type Superplasticizers for Concrete and their Working Mechanism**
Speaker: [Dr. Tsuyoshi Hirata](#) | Rudolf Diesel Industry Fellow
- July 19 Lecture Series “Science and Society – Meet with Excellence”
Unwägbarkeiten wissenschaftlicher Politikberatung – vom Klimawandel bis zur Energiewende
Organizers: Carl von Linde-Akademie, TUM-IAS
Speaker: [Prof. Peter Weingart](#) (Bielefeld University) | TUM Distinguished Affiliated Professor
- July 22–23 Workshop **The Role of Abstraction and Hierarchical Structures in Cognitive Systems**
Organizers: [Dr. Georg von Wichert](#) | Rudolf Diesel Industry Fellow
[Prof. Alexandra Kirsch](#) | Carl von Linde Junior Fellow
[Prof. Dongheui Lee](#) | Carl von Linde Junior Fellow
- Building cognitive technical systems requires techniques for perception, knowledge representation, learning, and action selection, which are up to the challenges posed by a complex, dynamic and uncertain world. Studying human cognition has shown that we use very sophisticated abstract representations to succeed in such environments. Abstraction allows for a concentration of the cognitive processes on essential concepts and thus “compresses” the problem spaces of prediction and planning tasks. It also fosters the generalization of concepts and solutions which is important to increase a system’s behavioral robustness.
- The use of abstraction as a constitutive feature of cognitive processes would however not only help to make technical systems more reliable and efficient, but also ease the interaction with users. Yet, general mechanisms for abstraction and how to use such representations to facilitate perception and action are still unknown. This workshop brought together researchers from technical fields with cognitive and social scientists to see what we could learn from naturally intelligent systems and how we could build similarly powerful abstraction mechanisms for technical systems in order to make them more flexible, adaptive and understandable for real-world applications.
- August 23 Talk **A Framework for Deflated BiCG and Related Solvers**
Organizer: TUM-IAS Focus Group High-Performance Computing (HPC)
Speaker: [Prof. Martin H. Gutknecht](#) (ETH Zurich)
- September 6 Talk **Analytic Continuation of Rough (Fractal) Objects**
Organizer: TUM-IAS Focus Group High-Performance Computing (HPC)
Speaker: [Prof. Michael Barnsley](#) (Australian National University)
- September 8–12 Course **Statistical Methods for Genome-Enabled Selection**
Organizer: [Prof. Daniel Gianola](#) | Hans Fischer Senior Fellow
- September 12 Inaugural Lecture **On Prediction of Complex Traits in Livestock and Plants**
Speaker: [Prof. Daniel Gianola](#) (University of Wisconsin-Madison) | Hans Fischer Senior Fellow

September 25 Talk **Intermolecular Interactions: From Simple Molecules to Biological Systems**
Speaker: [Dr. Sotiris Xantheas](#) (Pacific Northwest National Laboratory, USA) | TUM-
IAS Visiting Fellow

October 1–2 Workshop **Structural Reliability, Risk Assessment and Decision-Making: Past, Present, Future**
Organizers: [Prof. Armen Der Kiureghian](#) (University of California, Berkeley) | TÜV 127
Süd Stiftung Visiting Professor, [Prof. Daniel Straub](#) (Engineering Risk Analysis, TUM)

October 1–2 Workshop **Event-Based Control and Optimization**
Organizer: [Sandra Hirche](#) (Information-Oriented Control, TUM)
Speaker: [Brian D.O. Anderson](#) (ANU) | TUM-IAS Visiting Fellow

October 15 Talk **Elektromobilität - Das Fahrzeug der Zukunft: Vorausschauend, mitdenkend und verständnisvoll**
Organizer: TUM Mentoring
Speaker: [Prof. Gernot Spiegelberg](#) | Rudolf Diesel Industry Fellow

October 27 **Tag der offenen Tür**
Talk: **Eine kleine Reise durch die Welt der Teilchen – Neuigkeiten zur Higgs-Suche am Large Hadron Collider (LHC)**
Speaker: [Dr. Jennifer Girrbach](#) (Focus Group Fundamental Physics)
Exhibition: **Controlling a Robot Avatar over Distance**
[Dr. Angelika Peer](#) | Carl von Linde Junior Fellow



October 29 Talk **Technik und Verantwortung oder: wie die Ethik die Technik erreicht**
Award Ceremony for Prof. Jürgen Mittelstraß to “TUM Distinguished Affiliated Professor”
Speaker: [Prof. Jürgen Mittelstraß](#) (University of Konstanz)

October 30 Talk **Strategic Human Resource Management Focusing on its Influence on the Relation between Employee Turnover and Organizational Performance**
Speaker: [Prof. Jason D. Shaw](#) | TUM-IAS Visiting Fellow

November 8 Talk **Particle Accelerators to Present-Day Cancer Hadrontherapy**
Award Ceremony for Prof. Ugo Amaldi to “TUM Distinguished Affiliated Professor”
Speaker: [Prof. Ugo Amaldi](#) (University of Milano-Bicocca)

Lecture Series “Science and Society – Meet with Excellence”
**Coupled Human-Environment Systems – What do Observations
 and Models Tell us?**

Speaker: [Prof. Wolfram Mauser](#) (Ludwig-Maximilians-Universität München)

Organizers: MCTS, TUM-IAS

November 23

Liesel Beckmann Symposium 2012 Gender in Life Science



Organizers: TUM Center of Life and Food Sciences Weihenstephan, TUM.Diversity, Graduate Center Weihenstephan, TUM-IAS

TUM-IAS, together with the TUM Board on Gender Equality, has been co-sponsoring a series of Liesel Beckmann Symposia and Workshops that explore issues with gender research and gender diversity from various angles. The series is in honor of Liesel Beckmann (1941-1965) who was the first female professor at TUM. She was also the first chair holder in Germany in the area of Business Science. Although in many respects a great pioneer, she fitted into the TUM very well and blasted a path of normalcy for gender equality in its engineering environment. So far there have been five Liesel Beckmann Symposia, on very diverse topics: gender related medical issues, youth problems, women in research, education and, most recently life sciences in 2012 (described below). It should not be surprising that in each workshop not only very interesting research issues were treated, but also new issues have arisen that provided good motivation for further exploration. Although “gender” issues, in contrast to “sex-related” issues, have been considered mainly a topic for social sciences, there are enough technical questions arising to justify attention from the scientific and engineering community at TUM, especially when it concerns the connection between behavior and the design of new systems, or the collection and interpretation of data characterizing social systems and serving as input for engineering decision making. TUM-IAS supports the TUM move towards a better integration of technology with societal systems, in which gender plays such a great role.

The talks focused on the topic of gender in Agricultural Science, Silviculture, Biology, Food Science and Clinical Nutrition, thereby representing the subject range of the Center of Life and Food Sciences Weihenstephan (WZW). Excellent and internationally renowned speakers could be engaged for four talks, which took place in the morning, and four workshops in the afternoon, all of which contributed to the symposium’s ambitious and diversified program.

Patricia Howard, the editor of “Women and Plants: Gender Relations in Biodiversity Management and Conversation,” who is an internationally well-known expert in this subject, opened the symposium with a highly informative and interesting talk on “Women, Agrobiodiversity, and Tipping Points.” She elaborated on the various roles, relationships and interactions between women and the natural environment as can be found in various cultures, and focused on their importance for preserving biodiversity. In her talk about “Women in Agriculture,” in which she returned to our own culture and history, Simone Helmle took her audience on a fascinating and entertaining journey through time. Ina Bergheim asked “Different Gender, Different Food?” from a clinical nutrition point of view and explored gender-specific differences concerning the development of dietary-related diseases in children and adults. Then Mathilde Schmitt took up the topic of Agricultural Science again in

her talk on “Inclusion and Differentiation in Life Sciences, Seen through a Gender Perspective.” She critically reflected on structural obstacles that repeatedly lead to the marginalization and even exclusion of female scientists.

After a lunch break the participants spread out to several workshops, where time flew by thanks to lively discussions and exciting topics, with which many of the participants had not been familiar before. Christina Bauhardt asked “What Does Climate Have to Do with Gender”; she put up for discussion the correlation of ecology, resource policy and gender justice. The workshop guided by Elisabeth Mense discussed “subtle differences” in nutrition and examined the connection between nutrition, social inequality and gender. In the second round of workshops, Kerstin Palm suggested to critically challenge popular scientific theories on biological gender differences that entrench themselves into clichés in sayings such as “Men cannot listen, women cannot park properly.” Christine Katz pointed to “Where the Wild Things Are” in order to analyze the “male-dominated forestry”.

129

To conclude the symposium, the participants were invited to discuss the day’s many information and impressions in a familiar atmosphere at a small reception.

- November 26 Talk **Why So Few? Gender Stereotypes and Workplace Bias**
Speaker: [Prof. Madeline Heilman](#) | TUM-IAS Visiting Fellow
Organizers: [Prof. Isabell Welp](#) (Strategy and Organization, TUM),
TUM.Diversity, TUM-IAS
- November 28 Talk **Risk and Vulnerability of Large-scale Technical Systems: Challenges and Achievements**
Award Ceremony for Prof. Wolfgang Kröger to “TUM Distinguished Affiliated Professor“
Speaker: [Prof. Wolfgang Kröger](#) (ETH Zurich)
- December 6 Lecture Series “Science and Society – Meet with Excellence”
How I learned to stop worrying and love Fukushima – Zur Kommunikation großtechnischer Risiken und Chancen
Speaker: [Dr. Josef Oehmen](#) (MIT) | TÜV Süd Stiftung Visiting Professor
Organizers: MCTS, TUM-IAS



People





Carl von Linde Senior

- 2007 Prof. Andrzej Buras, Prof. Arthur Konnerth, Prof. Reiner Rummel
- 2008 Prof. Horst Kessler, Prof. Claudia Klüppelberg
- 2009 Prof. Axel Haase
- 2010 Prof. Gerhard Abstreiter, Prof. Ulrich Stimming
- 2011 Prof. Ingrid Kögel-Knabner

Carl von Linde Junior

- 2007 Prof. Adrian Jäggi
- 2008 Dr. Martin Gorbahn, Dr. Ulrich Rant, Prof. Robert Stelzer
- 2009 Dr. Kolja Kühnlenz, Dr. Julia Kunze-Liebhäuser, Dr. Marco Punta,
Dr. Ian Sharp
- 2010 Dr. Willi Auwärter, Dr. Vladimir García Morales, Dr. Alexandra Kirsch,
Dr. Miriam Mehl, Dr. Christian Stemberger, Dr. Dirk Wollherr
- 2011 Prof. Dongheui Lee, Dr. Angelika Peer

Hans Fischer Senior

- 2007 Prof. Gerhard Beutler, Prof. Walter Kucharczyk, Prof. Bert Sakmann
- 2008 Prof. Anuradha M. Annaswamy, Prof. Yasuhiko Arakawa, Prof. Douglas
Bonn, Prof. Mandayam A. Srinivasan, Prof. David A. Weitz
- 2009 Prof. Matthew Campbell, Prof. Richard Davis, Prof. Gino Isidori,
Prof. Shuit-Tong Lee, Prof. Wolfgang Porod, Prof. Stanley Riddell,
Prof. Peter Schröder, Prof. Zohar Yosibash
- 2010 Prof. Robijn Bruinsma, Prof. Markus Hegland, Prof. Stefan Pokorski,
Prof. Michael Ortiz, Prof. Tim Sparks, Prof. Raman I. Sujith,
- 2011 Prof. Silvio Aime, Prof. Polly L. Arnold, Prof. Daniel Gianola,
Prof. Frank Kschischang, Prof. Christian Werthmann
- 2012 Prof. Stephen Goodnick, Prof. Dietmar Hutmacher

Hans Fischer Junior

- 2012 Prof. George Biros, Dr. Franz Hagn

Hans Fischer Tenure Track

- 2007 Prof. Thomas Misgeld
- 2010 Prof. Hendrik Dietz

Rudolf Diesel Industry

- 2009 Prof. Khaled Karrai, Dr. Dragan Obradovic, Dr. Georg von Wichert
- 2010 Dr. Matthias Heller, Dr. Tsuyoshi Hirata, Dr. Chin Man W. Mok,
Prof. Gernot Spiegelberg
- 2012 Dr. René-Jean Essiambre, Dr. Michael Friebe, Dr. Bruno Schuermans

Honorary Fellows 2012

Alexander von Humboldt Professor

Prof. Matthias Tschöp | University of Cincinnati

Alexander von Humboldt Research Awardees

Honorary Hans Fischer Senior Fellows

Prof. Nigel Cooper | University of Cambridge, UK

Prof. Hoang Nguyen The | Hanoi Medical University, Vietnam

ERC Grantees

Prof. Noam Berger | Probability, TUM

Prof. Massimo Fornasier | Applied Numerical Analysis, TUM

Prof. Alexander Holleitner | Experimental Semiconductor Physics, TUM

Prof. Arthur Konnerth | Neuroscience, TUM

Prof. Christian Pfeleiderer | Experimental Physics, TUM

Prof. Jürgen Ruland | Clinical Chemistry and Pathobiochemistry, TUM

Prof. Andrey Rybalchenko | Foundations of Software Reliability and
Theoretical Computer Science, TUM

Prof. Markus Schwaiger | Clinic for Nuclear Medicine, TUM

Prof. Eva Viehmann | Algebra, TUM

Gottfried Wilhelm Leibniz Prizewinner

Prof. Barbara Wohlmuth | Numerical Mathematics, TUM

TUM Distinguished Affiliated Professors

Prof. Craig Calhoun | New York University

Prof. François Diederich | ETH Zurich

Prof. Steven D. Glaser | University of California

Prof. Wolfgang Kinzelbach | ETH Zurich

Prof. Klaus-Olaf von Klitzing | Max Planck Institute for
Solid State Research, Stuttgart

Prof. Peter Weingart | University Bielefeld

Visiting Fellows 2012

135

[Prof. George Biros](#)

Institute for Computational Engineering and Sciences
The University of Texas at Austin
Host: Dr. Miriam Mehl

[Prof. Kit. H. Bowen](#)

Department of Chemistry and Materials Science
Johns Hopkins University
Host: Prof. Ulrich Heiz

[Prof. Suh-Urk Chung](#)

Department of Physics
Brookhaven National Laboratory
Host: Prof. Stephan Paul

[Prof. Madeline E. Heilman](#)

Department of Psychology
New York University
Host: Prof. Isabell Welpé

[Prof. Dianne Newell](#)

Peter Wall Institute for Advanced Studies
University of British Columbia, Director (retired)

[Prof. Jason D. Shaw](#)

Carlson School of Management
University of Minnesota
Host: Prof. Isabell Welpé

[Prof. Arun Tangirala](#)

Department of Chemical Engineering
Indian Institute of Technology Madras
Host: Prof. Wolfgang Polifke

[Dr. Sotiris Xantheas](#)

Chemical and Materials Sciences Division
Pacific Northwest National Laboratory
Host: Prof. Alfred Laubereau

[Prof. Toshimitsu Yamazaki](#)

Department of Physics
University of Tokyo
Host: Prof. Walter Henning

Board of Trustees

The Board of Trustees is formed by a group of international advisors from academia, research support organizations, and industry. The International Board of Trustees advises the Director on general scientific, organizational, and technical issues. The Board also defines the general strategy and standards of the Institute.

Members

Chairman: Prof. Wolfgang A. Herrmann

Technische Universität München, President

Prof. Patrick Aebischer École Polytechnique Fédérale de Lausanne (EPFL), President

Dr. Enno Aufderheide Alexander von Humboldt Foundation, Secretary General

Dr. Christian Bode German Academic Exchange Service, Secretary General (retired)

Dr. Klaus Engel Evonik Industries AG, Chairman of the Executive Board

Prof. Manfred Erhardt Association for the Promotion of Science and Humanities in Germany, Secretary General (retired)

Prof. Angelika Görg Technische Universität München, Emerita Proteomics Research Group

Prof. Burkhard Göschel MAGNA International Europe AG, Chief Technical Officer, BMW Executive Board of Management (retired)

Prof. Joachim Hagenauer Technische Universität München, Emeritus Chair for Communications Engineering

Prof. Heather Hofmeister Goethe-Universität Frankfurt, The Center for Leadership and Behavior in Organizations (CLBO), Scientific Director

Hildegund Holzheid Bavarian Constitutional Court, President (retired)

Prof. Klaus-Olaf von Klitzing Max Planck Institute for Solid State Research, Professor of Physics, Nobel Prize in Physics 1985

Prof. Lars Pallesen Technical University of Denmark, President (retired)

Prof. Jürgen Mittelstraß University of Konstanz, Emeritus Chair of Philosophy

Prof. Bert Sakmann Max-Planck-Institute of Neurobiology, Max-Planck Florida Institute, Research Group Leader, Nobel Prize for Physiology or Medicine 1991

Prof. Janis Sarra Peter Wall Institute for Advanced Studies, University of British Columbia, Director

Dr. Georg Schütte Federal Ministry of Education and Research, State Secretary

Prof. Dr. med. Markus Schwaiger Technische Universität München, Clinic for Nuclear Medicine, Director

Prof. Frank E. Talke University of California, San Diego, Center for Magnetic Recording Research

Prof. Peter Wilderer Institute of Advanced Studies on Sustainability, Technische Universität München, Emeritus Chair of Water Quality Control and Waste Management

Advisory Council

TUM-IAS established its Advisory Council at the end of 2008, consisting of the main leaders of the TUM-IAS Focus Groups, and the leaders of related bodies in the Excellence Initiative as well as advisors closely connected with the Institute (14 in total).

The TUM-IAS Advisory Council functions as a standing advisory board to the TUM-IAS Director and his Management Team. One of its prime functions is advising on the suitability and ranking of nominations of Fellows in the various categories the Institute awards. In addition, the Council advises on the scientific and technological course of the Institute, on the basis of an assessment of the potential and needs of the University. The Advisory Council meets regularly, typically once every two months.

Members

Prof. Gerhard Abstreiter Chair of Experimental Semiconductor Physics

Prof. Hans-Joachim Bungartz Chair of Scientific Computing

Prof. Andrzej Buras Department of Physics

Prof. Martin Buss Institute of Automatic Control Engineering

Prof. Sandra Hirche Chair for Information-Oriented Control

Prof. Horst Kessler Department of Chemistry

Prof. Claudia Klüppelberg Chair of Mathematical Statistics at the Center for Mathematical Sciences

Prof. Ingrid Kögel-Knabner Chair of Soil Science

Prof. Arthur Konnerth Institute of Neuroscience

Prof. Gerhard Kramer Institute for Communications Engineering

Prof. Klaus Mainzer Chair of Philosophy and Philosophy of Science,
Director of the Munich Center for Technology in Society and the
Carl von Linde-Akademie

Prof. Ernst Rank Chair for Computation in Engineering,
Dean of the TUM Graduate School and Director of the IGSSE

Prof. Wolfgang A. Wall Institute for Computational Mechanics

Prof. Isabell Welp TUM School of Management - Chair for Strategy and Organization



Management Office

139

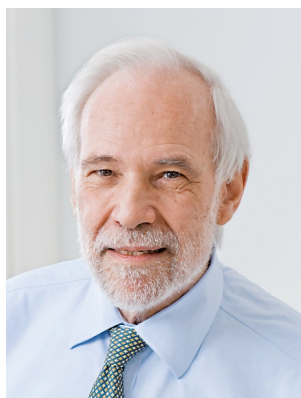

Prof. Patrick Dewilde
Director



Dr. Ana Santos Kühn
Managing Director
(until Oct. 2012)



Stefanie Hofmann
Managing Director
(since Oct. 2012)



Tatjana Steinberger
Program Manager



Anna Fischer
Program Manager



Sigrid Wagner
Event Manager /
Web Coordinator



Nina Jelinek
Secretary (Building
Coordination)



Christina Schmid
Secretary



Patrick Regan
Science Writer and Editor

A

Abstreiter 85
Advanced Cardiac Mechanics Emulator 60
Advanced Computation 48, 63
Advanced Construction Chemicals
and Materials 40
Advanced Stability Analysis 66
Aime 28
Aircraft Stability and Control 50
Arnold 22
Auwärter 86

B

Biochemistry 77
Biomedical Engineering 70
Biophysics 72, 74
Bruinsma 74

C

Campbell 48
C-H Activation Chemistry 22
Clinical Cell Processing and Purification 78
Cognitive Technology 24, 26, 52
Computational Biomechanics 67

D

Diesel Reloaded 56
Dietz 72

E

Essiambre 92

F

Fiber-Optic Communication and Information Theory 92
Fundamental Physics 88

G

García Morales 91
Gianola 30
Global Change 46

H

Haase 70
Hegland 64
Heller 50
High-Performance Computing (HPC) 64
Hirata 40

I

Isidori 88

K

Karrai 82
Kessler 77
Kirsch 52
Kögel-Knabner 44
Kschischang 92
Kühnlenz 52
Kunze-Liebhäuser 84

L

Lee 24

M

Mehl 64
Metropolis Nonformal 42
Misgeld 79
Molecular Aspects in Interface Science 84
Molecular Imaging 28

N

Nanoimprint and Nanotransfer 82
Nanophotonics 85
Nanoscale Control of Quantum Materials 86
Networked Dynamical Systems 55
Nonequilibrium Statistical Mechanics
at the Nanoscale 91

O

Obradovic 55
Ortiz 60

P

Peer 26
Pokorski 88
Porod 82

R

Riddell 78

S

Schröder 63
Soil Architecture 44
Sparks 46
Spiegelberg 56
Statistical and Quantitative Genomics 30
Stemberger 78
Sujith 66

W

Werthmann 42
Wichert 52
Wollherr 52

Y

Yosibash 67

142 Photo Credits/Copyright

4, 20, 25, 26, 27, 31, 40, 53 (von Wichert), 66, 79 (Konnerth), 84 (Kunze-Liebhäuser), 86 (Auwärter), 91, (García Morales), 115 (center left, right), 117 (left, center right, right), 139 (Steinberger): Photos Andreas Heddergott.

7, 29 (Aime), 34, 44, 46 (Sparks), 52 (Kirsch, Kühnlenz), 53 (Wollherr), 55 (Obradovic), 63 (Schröder), 64 (Mehl, Hegland), 67 (Yosibash), 68 (Haase), 72 (Dietz), 78, 79 (Misgeld), 82, 85 (Abstreiter), 88, 89, 92 (Kschischang), 98/99, 100, 101, 102, 103, 104, 105, 107, 108, 109, 113 (center left and right), 114, 115 (center right), 116 (left), 117 (center left), 120, 123, 127 (Girrbach), 132, 138, 139 (Dewilde, Santos Kühn, Hofmann, Regan): Photos Astrid Eckert.

42 (Werthmann), 77 (Kessler), 79 (Misgeld): facesbyfrank.

23 (Arnold): The University of Edinburgh.

24 (left): Alexander Schmidts, Dongheui Lee, and Angelika Peer, "Imitation Learning of Human Grasping Skills from Motion and Force Data", Proc. IEEE/RSJ International Conference on Intelligent Robots and Systems (IROS), pp. 1002–1007, 2011; (center): K. Hu and D. Lee, "Prediction-based Synchronized Human Walking Motion Imitation by a Humanoid Robot," *Automatisierungstechnik*, vol. 60, no. 11, pp. 705–714, 2012; (right): J.R. Medina Hernández, D. Lee, S. Hirche, "Risk-Sensitive Optimal Feedback Control for Haptic Assistance," IEEE International Conference on Robotics and Automation (ICRA), St. Paul, Minnesota, 2012, pp. 1025–1031.

28: G. Ferrauto, D. D. Castelli, E. Terreno, and S. Aime, "In vivo MRI visualization of different cell populations labeled with PARACEST agents," *Magn. Reson. Med.*, Jul. 2012. doi: 10.1002/mrm.24411.

29 (left): D. D. Castelli, G. Ferrauto, J. C. Cutrin, E. Terreno and S. Aime, "In vivo maps of extracellular pH in murine melanoma by CEST MRI", in *Magn. Reson. Med.*, accepted 8 January 2013 doi: 10.1002/mrm.24664. To be published online.

30: Prof. Daniel Gianola.

41: Nippon Shokupai Ltd., Japan.

42 (lower left and right): Gokce Iyicil.

43: Gokce Iyicil.

45: Courtesy of K. Heisler.

46 (right): Prof. Tim Sparks.

49: ASME 2013.

51 Figures 1, 2 and 4: TUM FSD; Figure 3: TUM.

52 (right): Institute of Automatic Control Engineering, TUM.

55: Figures 1 and 2: H. Mangesius, S. Hirche, and D. Obradovic, "Quasi-Stationarity of Electric Power Grid Dynamics Based on a Spatially Embedded Kuramoto Model," American Control Conference, Montreal, 2012, pp. 2159–2164.

56/57 Figures 1 and 2: TUM.

60/61 Figures 1 and 2: Simulation results produced by A. Nagler and C. Bertoglio; Figure 3: S. Heyden.

64/65 Figure 1: free usage; figure 2: Prof. Michael Bader; figure 3: Dr. Dirk Pflüger.

67: Focus Group Computational Biomechanics.

70/71 Figures 1 and 2: Prof. Axel Haase.

72 (except portrait photo Dietz): Dietz Lab, TUM.

74/75/76: Prof. Robijn Bruinsma.

80/81 Figure 1: C. Grienberger, N. L. Rochefort, H. Adelsberger, H. A. Henning, D. N. Hill, J. Reichwald, M. Staufenbiel, and A. Konnerth, "Staged decline of neuronal function in vivo in an animal model of Alzheimer's disease," *Nature Comm.*, vol. 3, 774, 2012. Figure 2: G. Plucińska, D. Paquet, A. Hruscha, L. Godinho, C. Haass, B. Schmid, and T. Misgeld, "In vivo imaging of disease-related mitochondrial dynamics in a vertebrate model system," *J. Neurosci.*, vol. 32, no. 46, pp. 16203–16212, 2012 (reproduced with permission of the journal).

84: Focus Group Molecular Aspects in Interface Science.

86: Dr. Knud Seufert, E20, TUM.

91 Figure 1: Dr. Vladimir García Morales.

128: Julie Rousset.

Imprint

143

Editors

Patrick Dewilde
Anna Fischer
Patrick Regan
Tatjana Steinberger

Designer

Christian Klette

Photographers

Astrid Eckert
Andreas Heddergott

Printed by

Druckerei Joh. Walch GmbH & Co, Augsburg

Publisher

Technische Universität München
Institute for Advanced Study
Lichtenbergstraße 2 a
85748 Garching
Germany
Phone: + 49.89.289.10550
Fax: + 49.89.289.10699
E-mail: info@tum-ias.de
Web: www.tum-ias.de



as of December 2012

TUM-IAS is sponsored by the Excellence Initiative, by the federal and state governments.

The background of the page is a solid blue color. Overlaid on this is a complex, abstract graphic consisting of numerous thin, wavy white lines that form a large, irregular shape. This shape has several internal white spaces and a prominent yellow-green curved band on its right side. The overall effect is reminiscent of a stylized map or a topographical contour plot.

Technische Universität München

Institute for Advanced Study

Lichtenbergstraße 2 a · 85748 Garching

Germany

Phone: + 49.89.289.10550

E-mail: info@tum-ias.de

Web: www.tum-ias.de